

Metal Oxide Varistor Data Sheet

Features

- TMOV integrated thermal protection device
- High peak surge current rating up to 15KA
- Designed to facilitate compliance to UL1449 for TVSS products
- Wide operating voltage (V_{1mA}) range from 150V to 1200V
- Rated current: 20A
- Rated Functioning Temperature: 136(°C)
- Fast responding to transient over-voltage and limited current
- Large absorbing transient energy capability
- Low clamping ratio and no follow-on current
- Three-lead version available for indication purposes
- Meets MSL level 1, per J-STD-020
- Operating Temperature: -40°C ~ +85°C
- Storage Temperature: -40°C ~ +85°C
- Safety certification: UL: E327997

Applications

- AC power line or AC/DC supplies
- Transistor, diode, IC, thyristor or triac semiconductor protection
- Surge protection in consumer electronics
- Surge protection in industrial electronics
- Surge protection in electronic home appliances, gas and petroleum appliances
- Relay and electromagnetic valve surge absorption
- AC panel protection Modules

Part number code

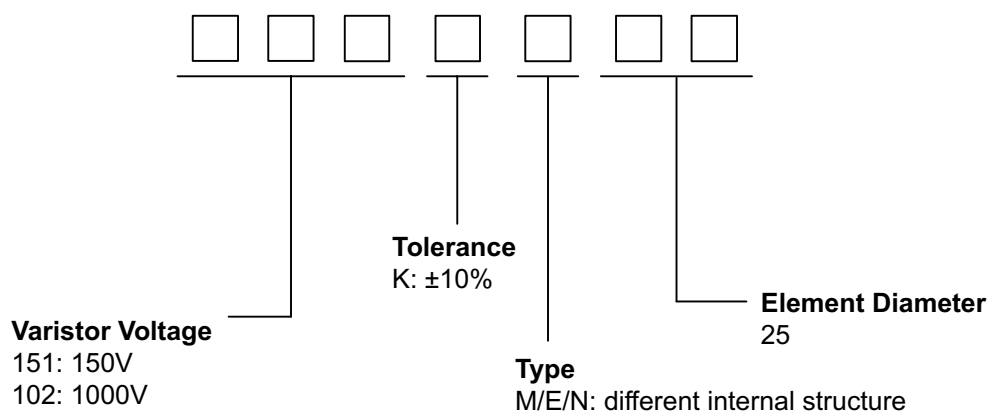

Lead configurations and application examples

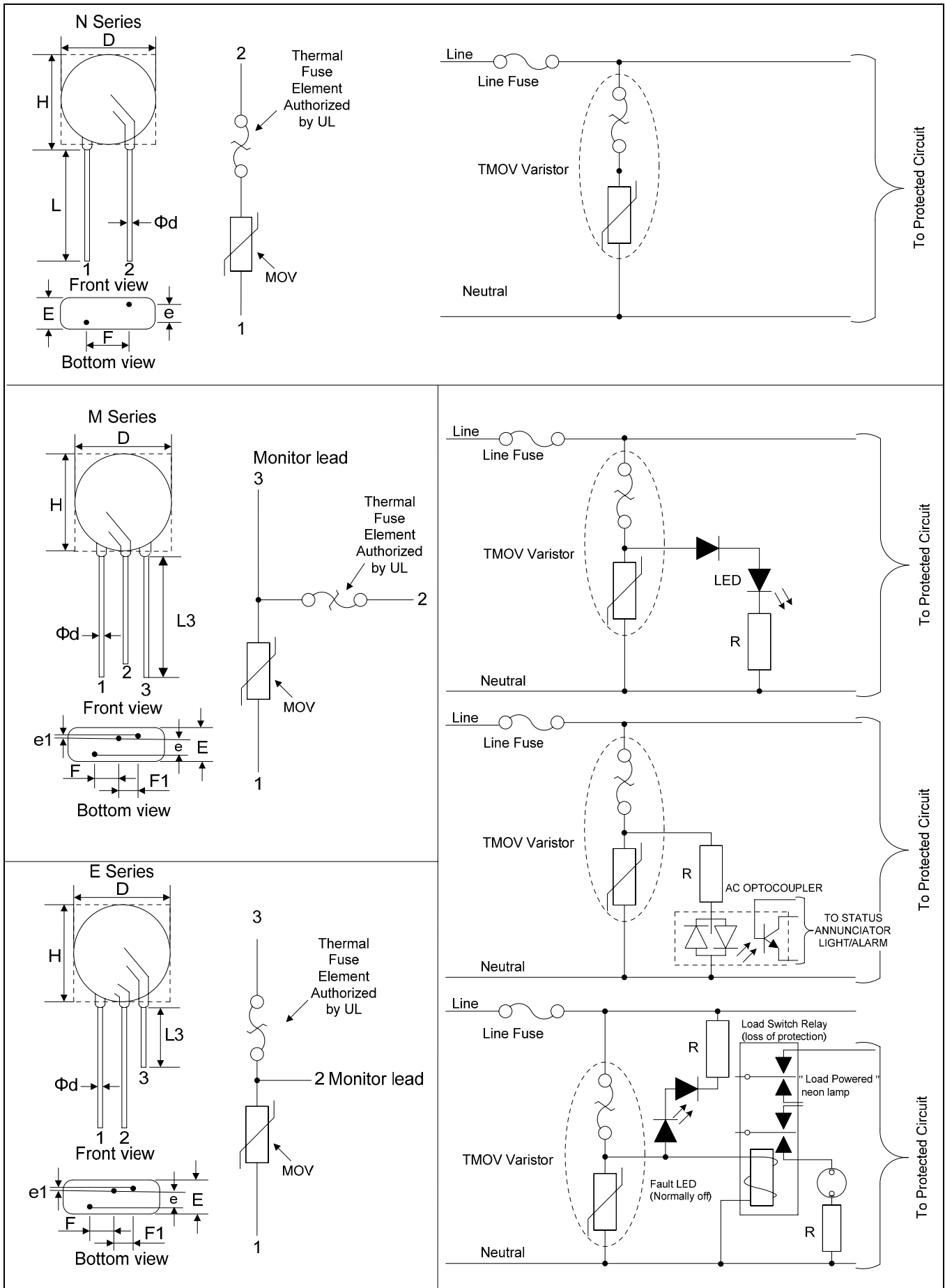

Dimensions

Symbol		BK'S M / E / N Varistor		
		25M	25E	25N
D (max.)		29.0	29.0	29.0
H (max.)		32.0	32.0	32.0
F (±1.0)		7.5	12.5 / 7.5	12.5 / 7.5
F1 (±1.0)		5.0	6.5 / 5.0	-
e Max.	151K~391K	3.8	3.8	3.8
	431K~621K	5.5	5.5	5.5
	681K~911K	7.8	7.8	7.8
	102K~122K	10.0	10.0	10.0
e1	151K~391K	2.3±1.0	2.3±1.0	--
	431K~621K			
	681K~911K			
	102K~122K			
E Max.	151K~391K	11.8	11.8	11.8
	431K~621K	13.5	13.5	13.5
	681K~911K	15.8	15.8	15.8
	102K~122K	18.0	18.0	18.0
L (min.)		20.0	20.0	20.0
L3 (min.)		10.0	10.0	-
Φd		1.0		

Electrical characteristics

Part Number	Maximum Allowable Voltage		Varistor Voltage $V_{1mA}(V)$	Maximum Clamping Voltage		Maximum Peak Current (8/20 μ s)		Maximum Energy (Joule)		Rated Power (W)	Typical Capacitance (Reference) @1KHz (pf)
	$V_{AC}(V)$	$V_{DC}(V)$		$I_P(A)$	$V_C(V)$	1 time	2 times	10/100 0 μ s	2ms		
			(A)								
151KM(E,N)25	95	125	150(135~165)	150	250	15000	12000	160	105	1.20	4300
181KM(E,N)25	115	150	180(162~198)	150	300	15000	12000	175	120	1.20	3500
201KM(E,N)25	130	170	200(185~225)	150	340	15000	12000	210	150	1.20	3200
221KM(E,N)25	140	180	220(198~242)	150	365	15000	12000	230	165	1.20	2900
241KM(E,N)25	150	200	240(216~264)	150	395	15000	12000	255	180	1.20	2650
271KM(E,N)25	175	225	270(243~297)	150	455	15000	12000	285	205	1.20	2400
301KM(E,N)25	190	250	300(270~330)	150	500	15000	12000	310	220	1.20	2100
331KM(E,N)25	210	275	330(297~363)	150	550	15000	12000	325	231	1.20	1900
361KM(E,N)25	230	300	360(324~396)	150	595	15000	12000	340	240	1.20	1750
391KM(E,N)25	250	320	390(351~429)	150	650	15000	12000	360	250	1.20	1600
431KM(E,N)25	275	350	430(387~473)	150	710	15000	12000	440	310	1.20	1500
471KM(E,N)25	300	385	470(423~517)	150	775	15000	12000	490	345	1.20	1400
511KM(E,N)25	320	415	510(459~561)	150	845	15000	12000	530	370	1.20	1250
561KM(E,N)25	350	460	560(504~616)	150	920	15000	12000	560	390	1.20	1150
621KM(E,N)25	385	505	620(558~682)	150	1025	15000	12000	590	410	1.20	1050
681KM(E,N)25	420	560	680(612~748)	150	1120	15000	12000	620	430	1.20	950
751KM(E,N)25	460	615	750(675~825)	150	1240	15000	12000	630	440	1.20	850
781KM(E,N)25	485	640	780(702~858)	150	1290	15000	12000	675	470	1.20	800
821KM(E,N)25	510	670	820(738~902)	150	1355	15000	12000	690	480	1.20	750
911KM(E,N)25	550	745	910(819~1001)	150	1500	15000	12000	715	500	1.20	700
102KM(E,N)25	625	825	1000(900~1100)	150	1650	15000	12000	750	505	1.20	650
112KM(E,N)25	680	895	1100(990~1210)	150	1815	15000	12000	780	550	1.20	600
122KM(E,N)25	750	990	1200(1080~1320)	150	1980	15000	12000	840	590	1.20	550

Mechanical Characteristics

Items	Test conditions / Methods	Specifications								
Tensile Strength of Terminals	Gradually applying the force specified and keeping the unit fixed for 10±1 sec. <table border="1" style="margin-left: auto; margin-right: auto;"> <thead> <tr> <th>Terminal diameter (mm)</th> <th>Force (kg)</th> </tr> </thead> <tbody> <tr> <td>0.5<d≤0.8</td> <td>1.0</td> </tr> <tr> <td>0.8<d≤1.25</td> <td>2.0</td> </tr> <tr> <td>1.25<d</td> <td>4.0</td> </tr> </tbody> </table>	Terminal diameter (mm)	Force (kg)	0.5<d≤0.8	1.0	0.8<d≤1.25	2.0	1.25<d	4.0	No visible damage $ \Delta V_{1mA}/V_{1mA} \leq 5\%$
Terminal diameter (mm)	Force (kg)									
0.5<d≤0.8	1.0									
0.8<d≤1.25	2.0									
1.25<d	4.0									
Bending Strength of Terminals	Hold specimen and apply the force specified below to each lead. Bend the specimen to 90°, then return to the original position. Repeat the procedure in the opposite direction. <table border="1" style="margin-left: auto; margin-right: auto;"> <thead> <tr> <th>Terminal diameter (mm)</th> <th>Force (kg)</th> </tr> </thead> <tbody> <tr> <td>0.5<d≤0.8</td> <td>0.5</td> </tr> <tr> <td>0.8<d≤1.25</td> <td>1.0</td> </tr> <tr> <td>1.25<d</td> <td>2.0</td> </tr> </tbody> </table>	Terminal diameter (mm)	Force (kg)	0.5<d≤0.8	0.5	0.8<d≤1.25	1.0	1.25<d	2.0	No visible damage $ \Delta V_{1mA}/V_{1mA} \leq 5\%$
Terminal diameter (mm)	Force (kg)									
0.5<d≤0.8	0.5									
0.8<d≤1.25	1.0									
1.25<d	2.0									
Vibration	Frequency range: 10~55 Hz Amplitude: 0.75mm or 98m/s ² Direction: 3 mutually perpendicular directions, 2hrs each.	No visible damage $ \Delta V_{1mA}/V_{1mA} \leq 5\%$								
Solder ability	Solder Temp: 245±5°C Dipping Time: 2±0.5 sec	At least 95% of terminal electrode is covered by new solder								
Resistance to Soldering Heat	Solder Temp: 260±5°C Dipping Time: ≤10 sec	No visible damage $ \Delta V_{1mA}/V_{1mA} \leq 10\%$								

Reliability

Items	Test conditions / Methods	Specifications															
High Temperature Storage	Ambient Temp: 85±2°C Duration: 1000hrs	$ \Delta V_{1mA}/V_{1mA} \leq 5\%$															
Low Temperature Storage	Ambient Temp: -40±2°C Duration: 1000hrs	$ \Delta V_{1mA}/V_{1mA} \leq 5\%$															
Humidity	Ambient Temp: 40±2°C, 90~95% R.H. Duration: 1000hrs	$ \Delta V_{1mA}/V_{1mA} \leq 5\%$															
Temperature Cycle	The conditions shown below shall be repeated 5 cycles <table border="1" style="margin-left: auto; margin-right: auto;"> <thead> <tr> <th>Step</th> <th>Temperature (°C)</th> <th>Period (minutes)</th> </tr> </thead> <tbody> <tr> <td>1</td> <td>-40±3</td> <td>30±3</td> </tr> <tr> <td>2</td> <td>Room temperature</td> <td>15±3</td> </tr> <tr> <td>3</td> <td>85±3</td> <td>30±3</td> </tr> <tr> <td>4</td> <td>Room temperature</td> <td>15±3</td> </tr> </tbody> </table>	Step	Temperature (°C)	Period (minutes)	1	-40±3	30±3	2	Room temperature	15±3	3	85±3	30±3	4	Room temperature	15±3	No visible damage $ \Delta V_{1mA}/V_{1mA} \leq 5\%$
Step	Temperature (°C)	Period (minutes)															
1	-40±3	30±3															
2	Room temperature	15±3															
3	85±3	30±3															
4	Room temperature	15±3															
High Temperature Load	Ambient Temp: 85±2°C Duration: 1000hrs Load: Max. Allowable Voltage In AC eara.	$ \Delta V_{1mA}/V_{1mA} \leq 10\%$															
Damp Heat Load	Ambient Temp: 40±2°C, 90~95% R.H. Duration: 1000hrs Load: Max. Allowable Voltage	No visible damage $ \Delta V_{1mA}/V_{1mA} \leq 10\%$															
Voltage Proof	Metal balls method, 2500Vac 1 min.	No visible damage															

Maximum Leakage Current and Maximum Clamping Voltage Curve

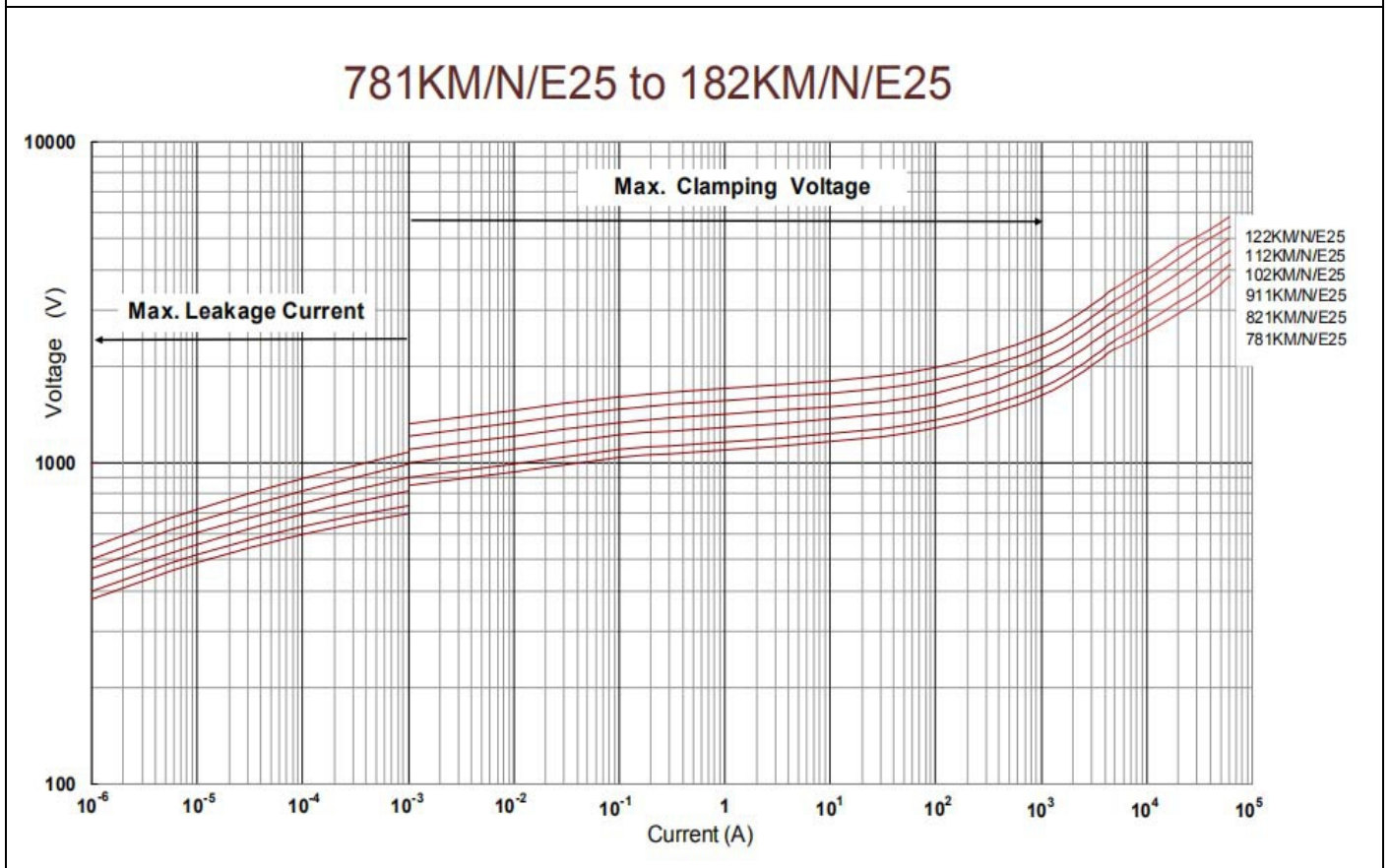
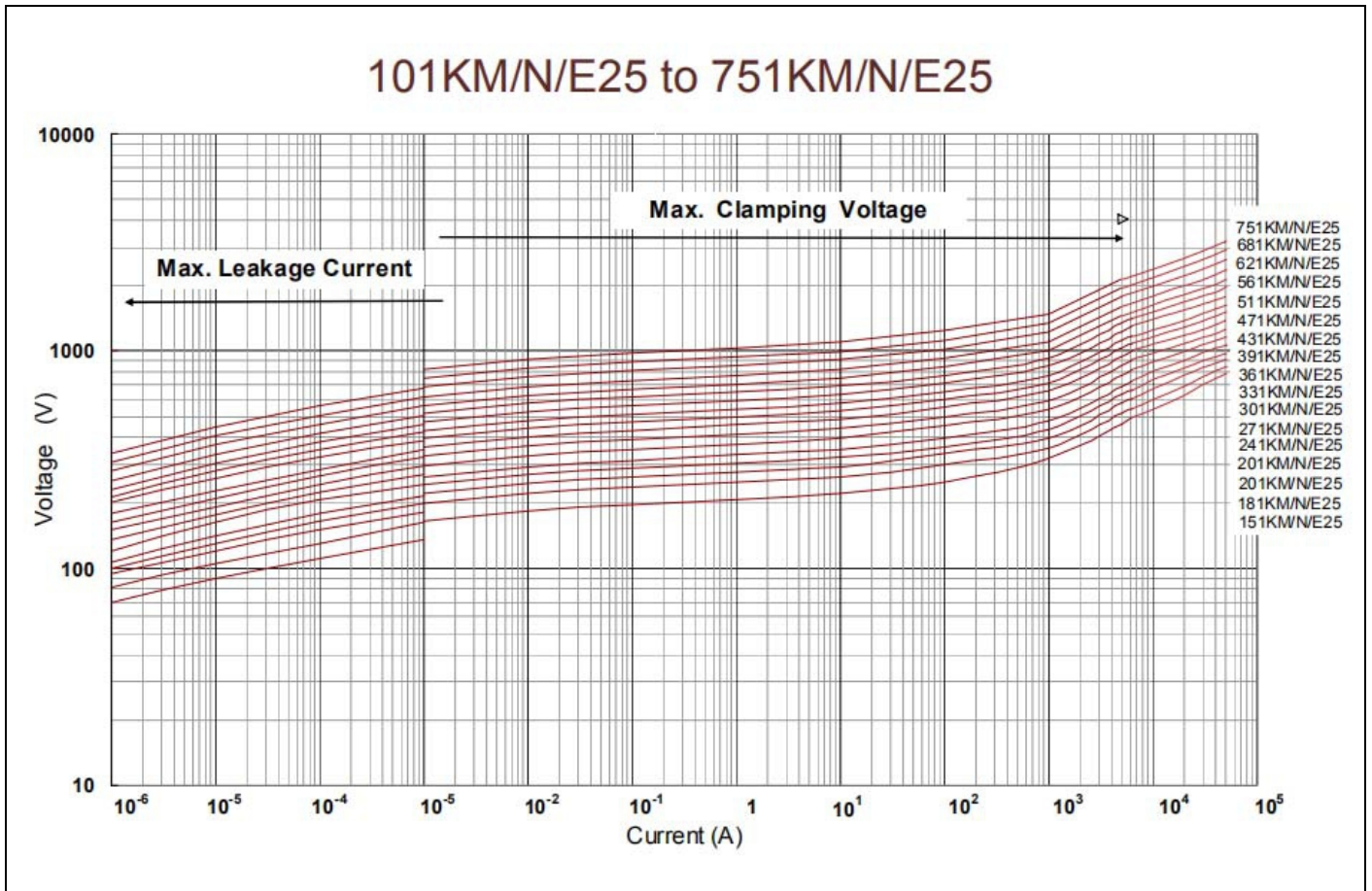

Maximum Surge Current Derating Curve

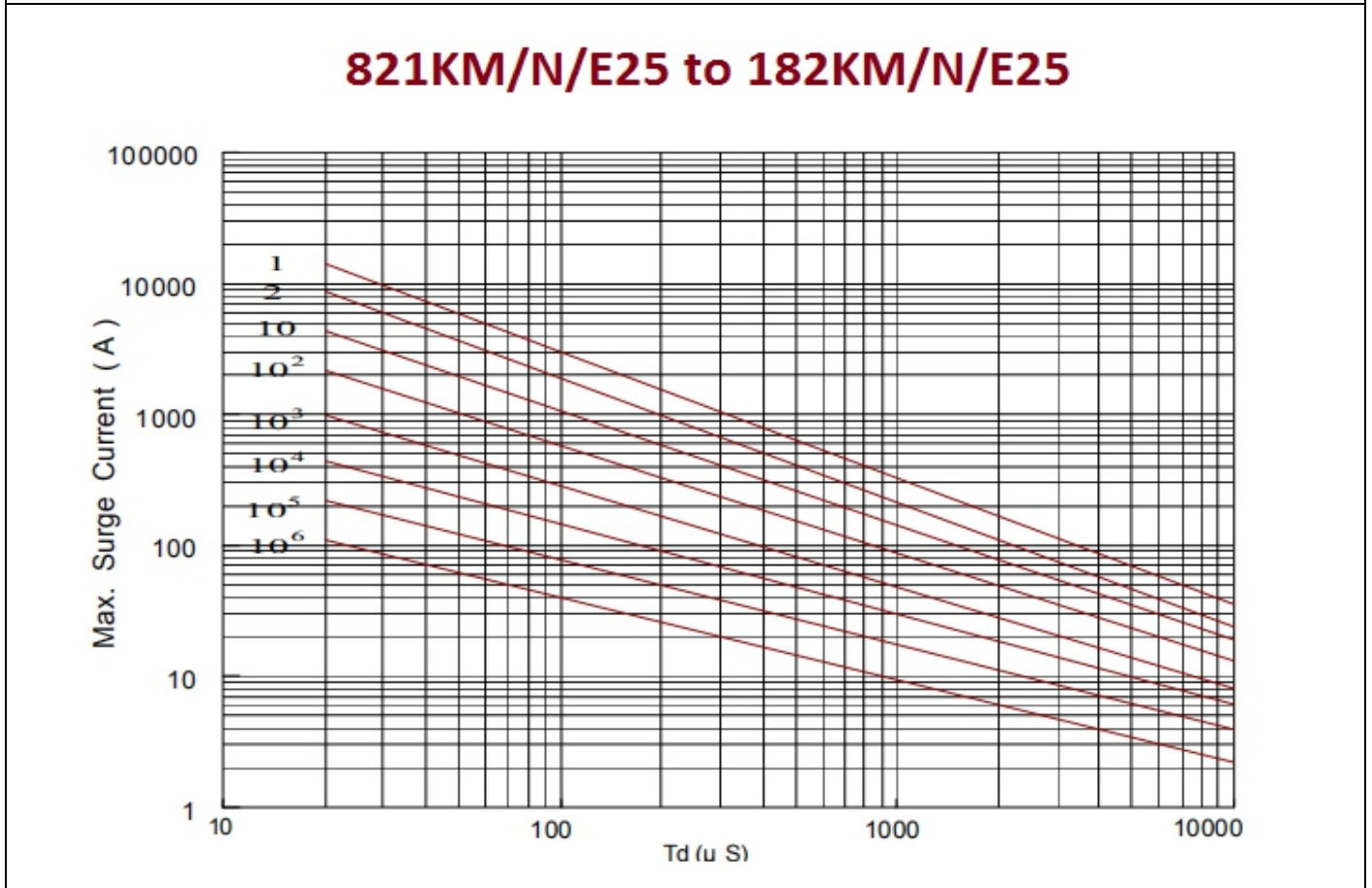
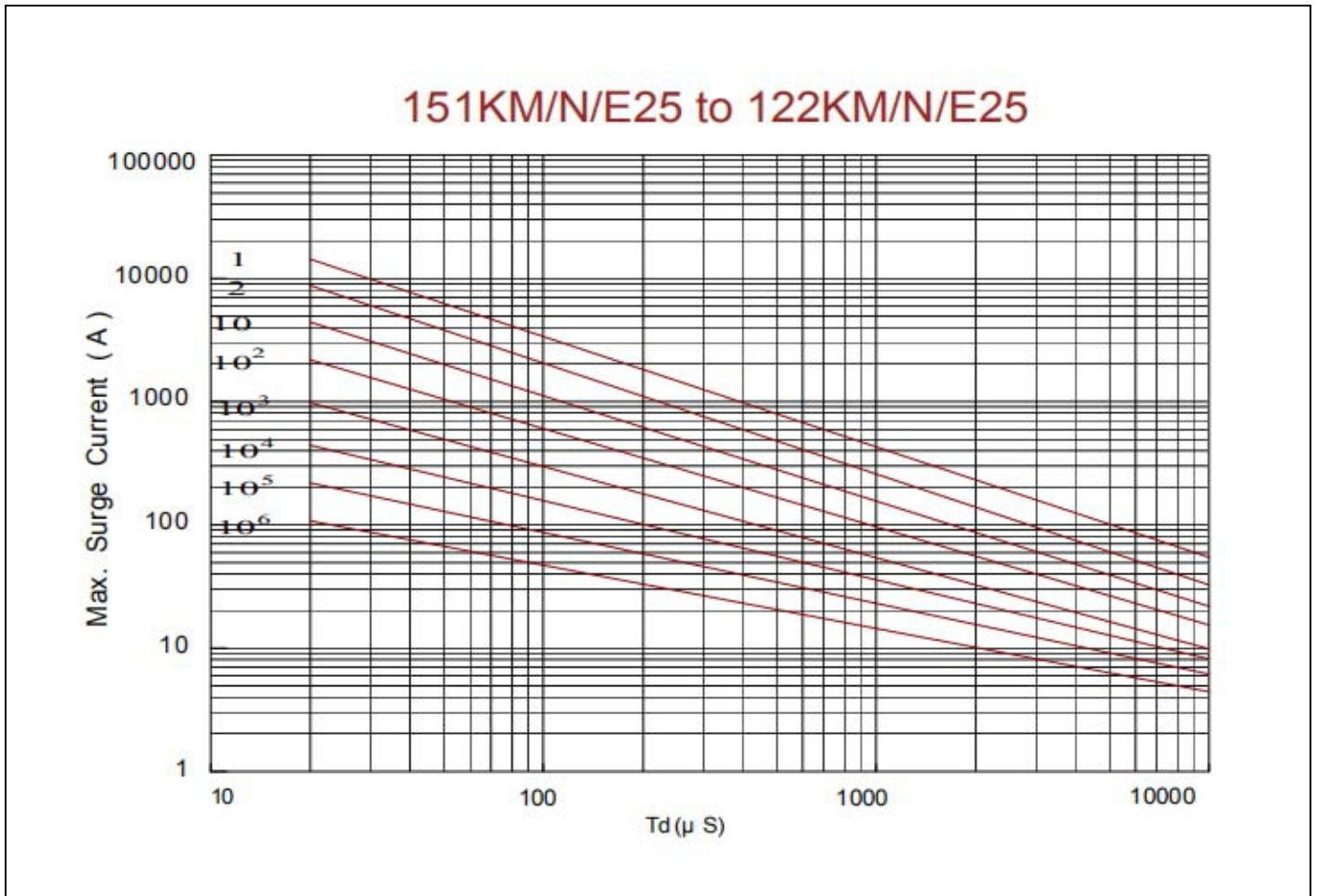

Soldering Recommendation

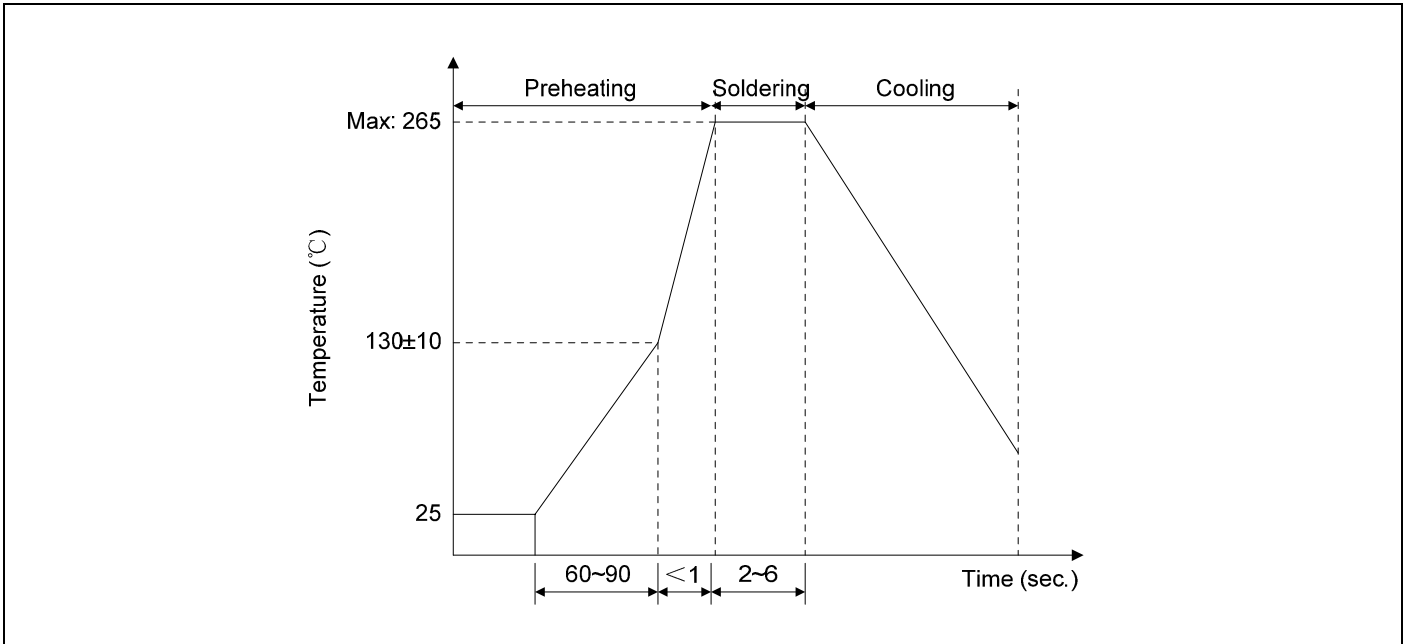

Marking code

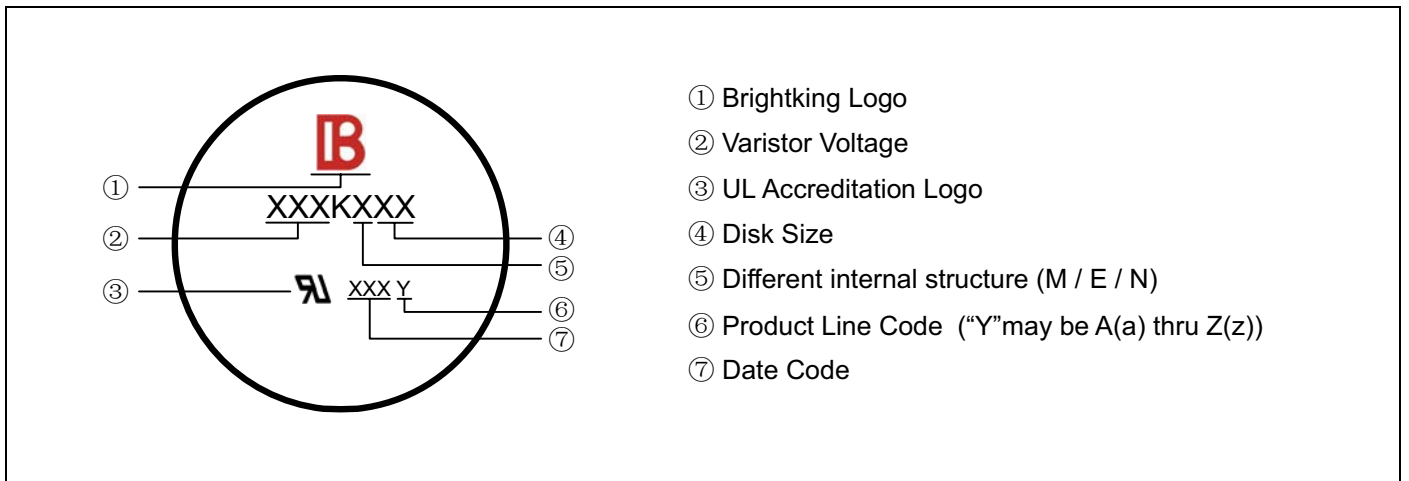

Quantity

Packaging Dimensions (Unit: mm)	Quantity
<p>Bulk</p> 	<p>50pcs/bag 2bags/box</p>