

## Metal Oxide Varistor (MOV) Data Sheet

### Features

- Wide operating voltage ( $V_{1mA}$ ) range from 100V to 1600V
- Fast responding to transient over-voltage
- Large absorbing transient energy capability
- Low clamping ratio and no follow-on current
- Meets MSL level 1, per J-STD-020
- Operating Temperature:  $-40^{\circ}\text{C} \sim +85^{\circ}\text{C}$
- Storage Temperature:  $-40^{\circ}\text{C} \sim +125^{\circ}\text{C}$
- Safety certification: UL: E327997  
CSA: 246579



### Applications

- Transistor, diode, IC, thyristor or triac semiconductor protection
- Surge protection in consumer electronics
- Surge protection in industrial electronics
- Surge protection in electronic home appliances, gas and petroleum appliances
- Relay and electromagnetic valve surge absorption

### Part number code

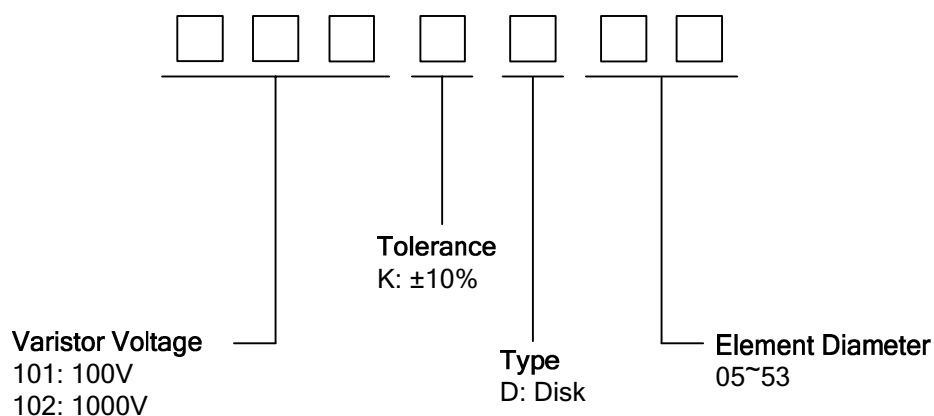

Dimensions

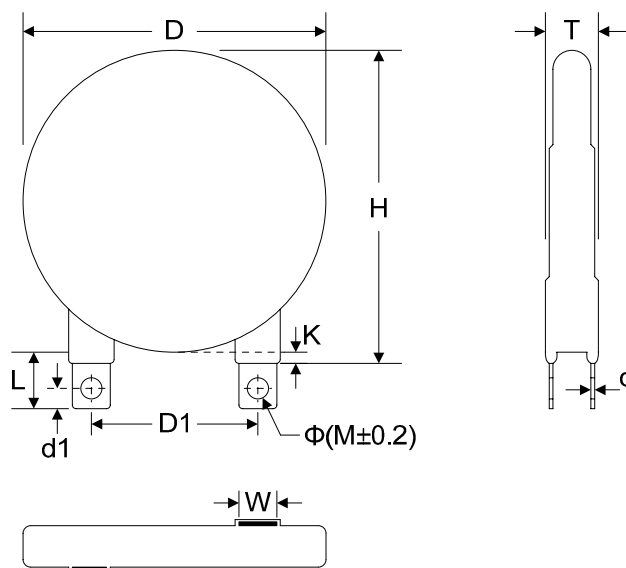

TABLE 1		Unit: mm	
Symbol	Dimension		
H(max.)	48.0	101K	
L(min.)	14.5	121K	
D(max.)	42.0	151K	
D1( $\pm 1.0$ )	25.4	181K	
T(max.)	TABLE 2	201K	
d( $\pm 0.25$ )	0.5	221K	
d1( $\pm 0.3$ )	3.7	241K	
K(max.)	3.2	271K	
W( $\pm 0.5$ )	7.0	301K	
$\Phi M(\pm 0.2)$	3.2	331K	
	361K	7.1	112K
		391K	
		431K	
		471K	

TABLE 2				Unit: mm	
Model	T(max.)	Model	T(max.)		
5.8	511K	8.0			
5.9	561K	8.3			
6.0	621K	8.7			
6.1	681K	9.0			
6.2	751K	9.4			
6.3	781K	9.6			
6.4	821K	9.8			
6.6	911K	10.4			
6.8	951K	10.6			
6.9	102K	11.2			
7.3	122K	12.3			
7.5	142K	13.3			
7.8	162K	14.3			

## Electrical characteristics

Part Number	Maximum Allowable Voltage		Varistor Voltage	Maximum Clamping Voltage		Withstanding Surge Current	Maximum Energy (10/1000μs)	Typical Capacitance (Reference)
	V <sub>AC</sub> (V)	V <sub>DC</sub> (V)	V <sub>1mA</sub> (V)	I <sub>P</sub> (A)	V <sub>C</sub> (V)	I (A)	(J)	@1KHz (pf)
101KD40	60	85	100(90~110)	300	165	40000	241	12100
121KD40	75	100	120(108~132)	300	200	40000	286	10600
151KD40	95	125	150(135~165)	300	250	40000	300	9500
181KD40	115	150	180(162~198)	300	300	40000	330	8900
201KD40	130	170	200(180~220)	300	340	40000	370	8400
221KD40	140	180	220(198~242)	300	360	40000	400	8200
241KD40	150	200	240(216~264)	300	395	40000	430	8000
271KD40	175	225	270(243~297)	300	455	40000	470	7600
301KD40	190	250	300(270~330)	300	500	40000	510	7300
331KD40	210	275	330(297~363)	300	550	40000	550	6700
361KD40	230	300	360(324~396)	300	595	40000	570	6200
391KD40	250	320	390(351~429)	300	650	40000	590	5100
431KD40	275	350	430(387~473)	300	710	40000	660	4900
471KD40	300	385	470(423~517)	300	775	40000	720	4300
511KD40	320	415	510(459~561)	300	845	40000	770	4200
561KD40	350	460	560(504~616)	300	925	40000	810	4000
621KD40	385	505	620(558~682)	300	1025	40000	860	3800
681KD40	420	560	680(612~748)	300	1120	40000	900	3500
751KD40	460	615	750(675~825)	300	1240	40000	940	3200
781KD40	485	640	780(702~858)	300	1290	40000	980	3000
821KD40	510	670	820(738~902)	300	1355	40000	1080	2900
911KD40	550	745	910(819~1001)	300	1500	40000	1150	2200
951KD40	575	765	950(855~1045)	300	1570	40000	1200	2000
102KD40	625	825	1000(900~1100)	300	1650	40000	1260	1800
112KD40	680	895	1100(990~1210)	300	1815	40000	1380	1600
122KD40	750	990	1200(1080~1320)	300	1980	40000	1460	1500
142KD40	880	1140	1400(1260~1540)	300	2310	40000	1550	1300
162KD40	1000	1280	1600(1440~1760)	300	2640	40000	1700	1150

**Soldering Recommendation**

Wave Lead Free Soldering Recommendation

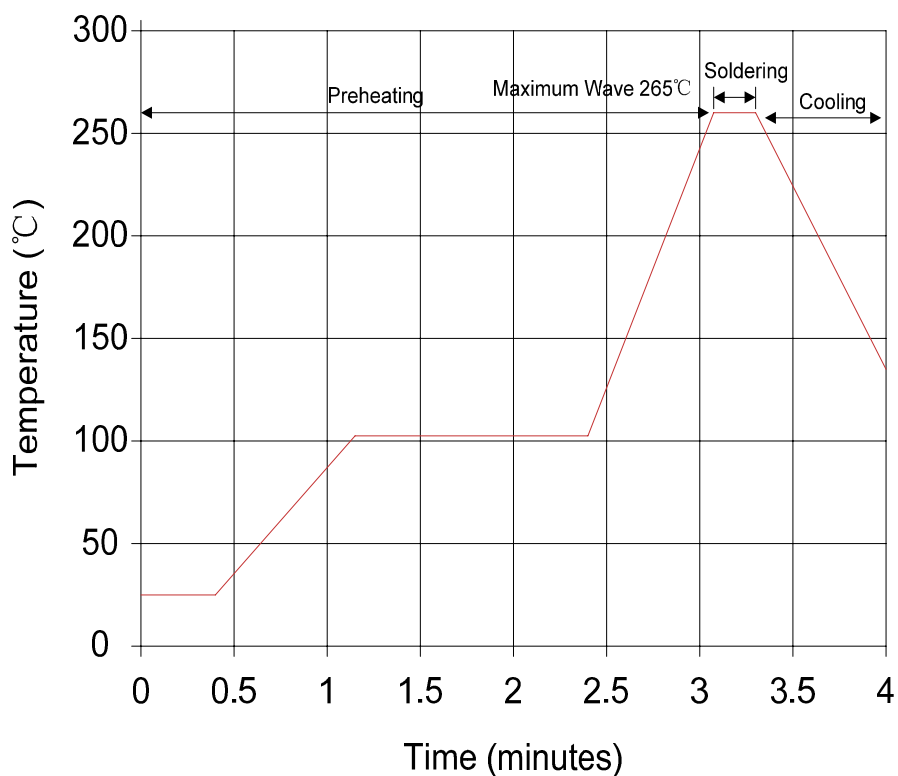

Item	Conditions
Peak Temperature	265°C
Dipping Time	10 seconds (max.)
Soldering	1 time

Recommendation Reworking Conditions with Soldering Iron

Item	Conditions
Temperature of Soldering Iron-tip	360°C (max.)
Soldering Time	3 seconds (max.)
Distance from Varistor	2mm (min.)

Marking code

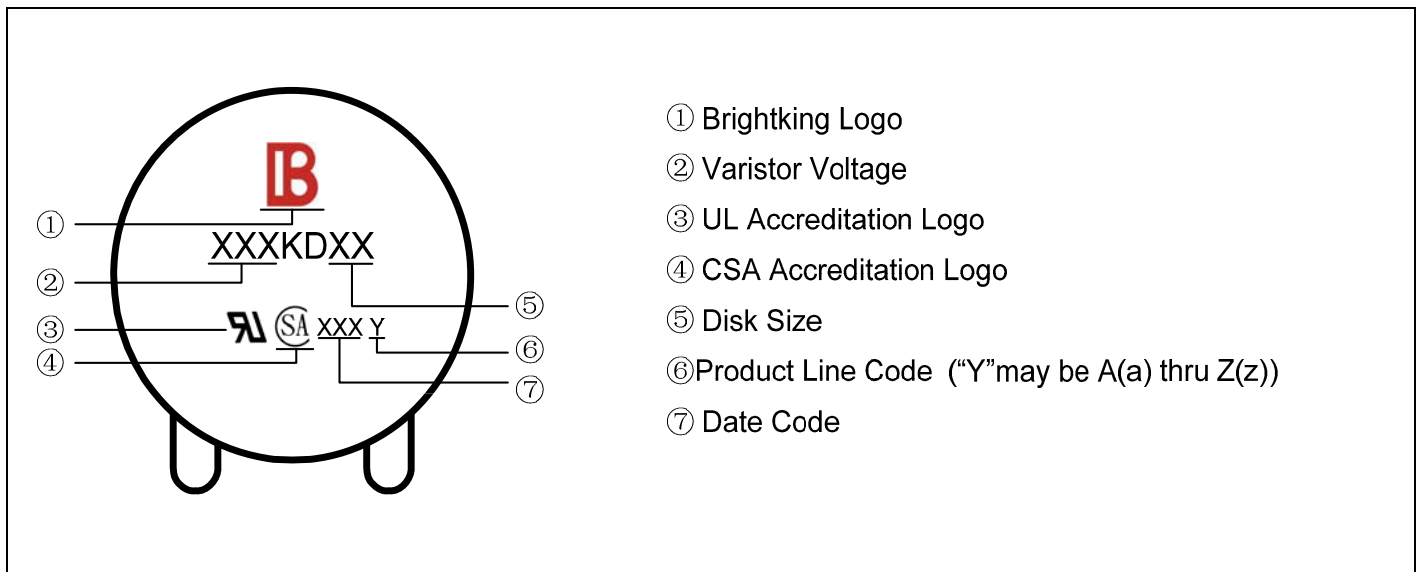

Quantity

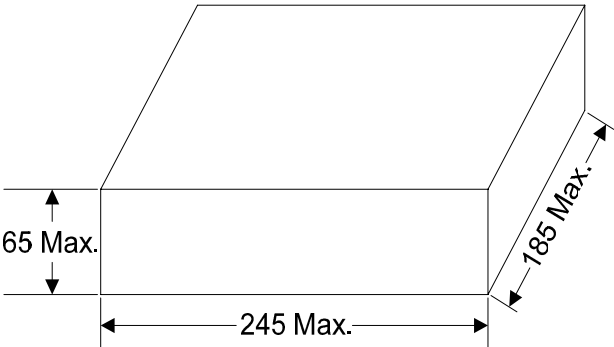
Packaging Dimensions (Unit: mm)	Quantity
<p>Bulk</p> 	<p>60pcs/box (101K~511K)</p>
	<p>32pcs/box (561K~162K)</p>