

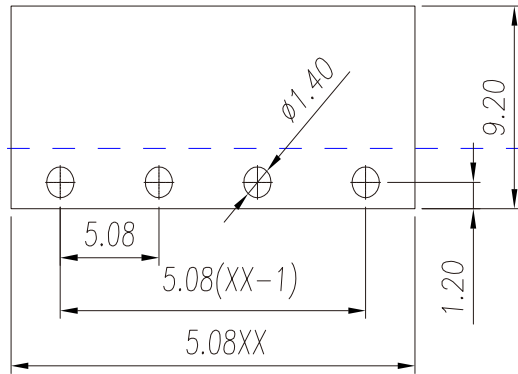

浙江连芯电子技术有限公司

Zhejiang Lianxin Electronic Technology Co.,Ltd

产品规格书
THE SPEC SHEET



P.C.B. LAYOUT

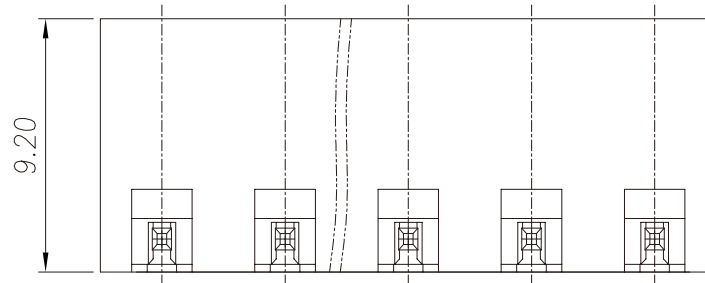
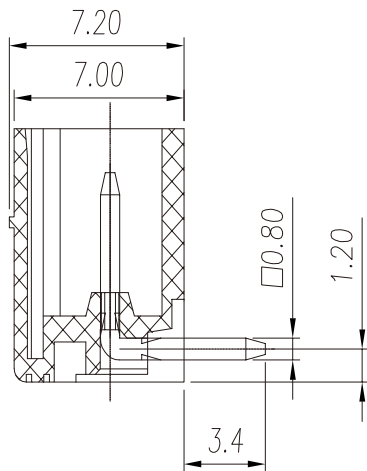
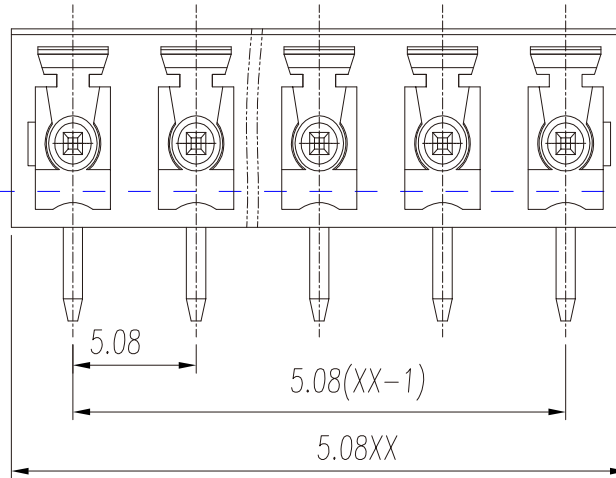

参考标准/Standard	UL	IEC
额定电压/Rated voltage	300V	250V
额定电流/Rated current	8A	7A
接触电阻/Contact resistanc	20MΩ	
绝缘电阻/Insulation resistance	500MΩ/DC500V	
使用线径/Wire range		
耐电压 /Wrth standing voltage	AC2000V/1Min	
机械性能/Mechanical		
扭矩/Torque		
温度范围/Temp. Range	-40℃~+105℃	
瞬间温度/MAX Soldering	+250℃5秒	
尺寸/Dimensins		
间距/Pitch	5.08mm	
极数/Poles		
材质及电镀/Material		
塑件/Housing	PA66,UL94V-0	
螺丝/Screws		
焊针/Welding needle	黄铜, 镀锡	

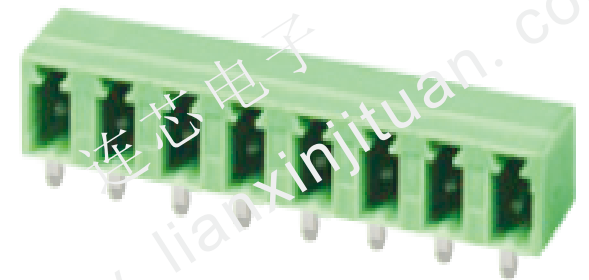

linear dimension(Tolerances Standard GB/T 14486-2008)											≡	—	□	//	⊥	
variable range	to 6	over 6 to 10	over 10 to 18	over 18 to 30	over 30 to 50	over 50 to 80	over 80 to 120	over 120 to 160	over 160 to 200	over 200 to 250	all	to 5	over 5 to 30	over 30 to 120	over 120 to	
	tolerance	±0.1	±0.14	±0.19	±0.25	±0.32	±0.43	±0.57	±0.72	±0.88	±1.05	±1.25	0.5	0.025	0.06	0.12

单位 / UNITS mm 尺寸 / SIZE A4 比例 / SCALE 3:1

第三视角 / THIRD ANGLE PROJECTION

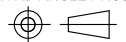

浙江连芯电子技术有限公司
LXLYM Zhejiang Lianxin Electronic Technology Co.,Ltd

名称
TITLE LXLYM -15EDGRC