

备有多种方形插座和圆形插座的表面连接和背面连接型

- 备有指触保护型。
- 备有固定支架、PYF用的跨接片。
- 新增无螺钉系列。

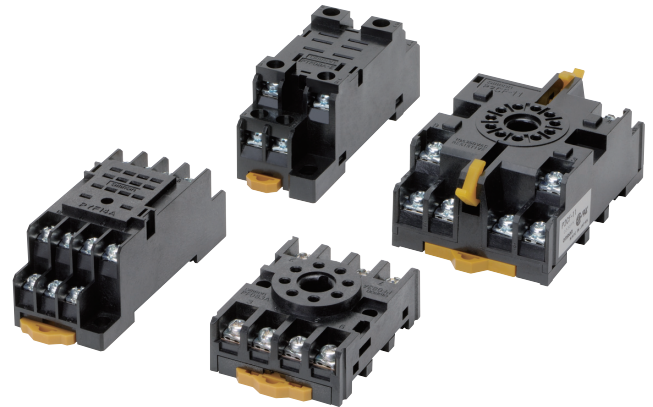

有关标准认证机型的最新信息，请参见本公司网站（www.fa.omron.com.cn）的“标准认证/适用”。

种类



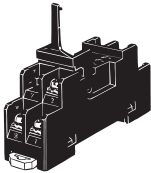
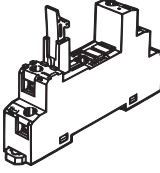
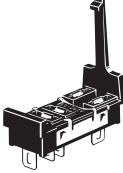
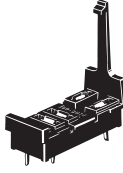
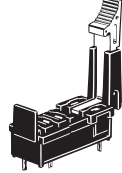
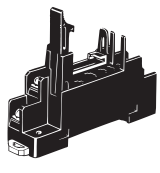
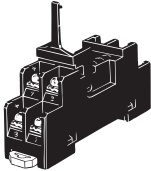
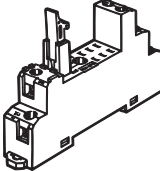
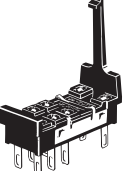
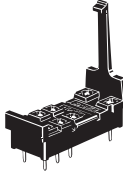
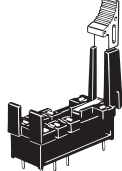







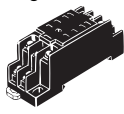
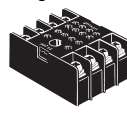
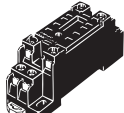

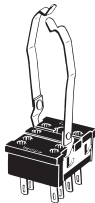
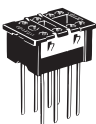

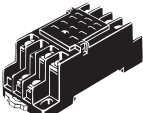
● 方形插座

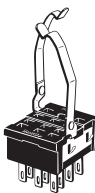
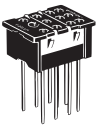
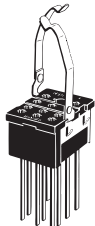
形状 插脚数	P2RF（表面连接）第8页		P2R（背面连接）第9~10页			P7TF（表面连接） 第10页
			焊接端子	印刷电路板用端子		
5脚	P2RF-05 约27g 	P2RF-05-E * 约38g 	P2R-05A 约5g 	P2R-05P 约5g 	P2R-057P 约5.5g 	P7TF-05 约28g 
8脚	P2RF-08 约33g 	P2RF-08-E * 约38g 	P2R-08A 约5g 	P2R-08P 约5g 	P2R-087P 约5.5g 	—

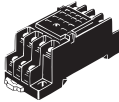
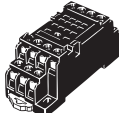
注1. -E型为指触保护结构。不能使用圆形端子。请使用Y形端子等。

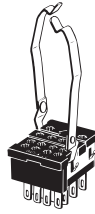
2. 拆下继电器时，在拉动插座杆的同时，用手指按住杆对侧的继电器外壳部分，边晃动边予以拔下。



* 本产品螺钉的紧固，请使用1号螺丝刀。

形状 插脚数	PYF (表面连接) 第11~12页		PY (背面连接) 第13页				
			焊接端子		研磨端子		印刷电路板用端子
8脚	PYF08A 约32g  PYF08M 约26g  PYF08A-E *1 	PY08 约8g  PY08-Y1 PY08-Y3 	PY08QN 约12g PY08QN2 	PY08QN-Y1 PY08QN2-Y1 	PY08-02 *2 约7.2g 		
11脚	PYF11A 约43g 	PY11 约9g  PY11-Y1 	PY11QN PY11QN2 	PY11QN-Y1 PY11QN2-Y1 	PY11-02 *2 		
14脚	PYF14A 约49g  PYF14A-E *1 	PY14 约10g  PY14-Y1 PY14-Y3 	PY14QN 约14g PY14QN2 	PY14QN-Y1 PY14QN2-Y1 PY14QN-Y3 PY14QN2-Y3 	PY14-02 *2 		

注: -E型为指触保护结构。不能使用圆形端子。请使用Y形端子等。

*1 本产品螺钉的紧固, 请使用1号螺丝刀。

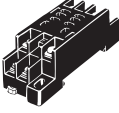
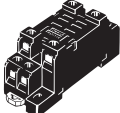
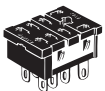
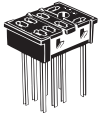
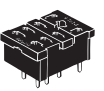
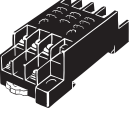
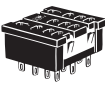
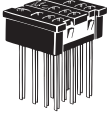
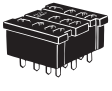
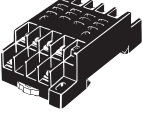
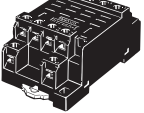
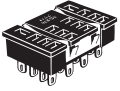
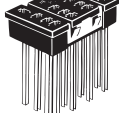
*2 不是耐助焊剂构造。为手动焊接推荐产品。

形状 插脚数	PTF (表面连接) 第14页		PT (背面连接) 第15页		
			焊接端子	研磨端子	印刷电路板用端子
8脚	PTF08A 约47g 	PTF08A-E *1 	PT08 约11g 	PT08QN 约10.4g 	PT08-0 *2 约8g 
11脚	PTF11A 约61g 		PT11 约13g 	PT11QN 	PT11-0 *2 约12.2g 
14脚	PTF14A 约77g 	PTF14A-E *1 	PT14 约17g 	PT14QN 约20g 	PT14-0 *2 约16.2g 

注: -E型为指触保护结构。不能使用圆形端子。请使用Y形端子等。

*1 本产品螺钉的紧固, 请使用1号螺丝刀。



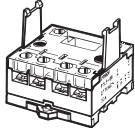







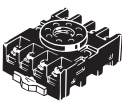
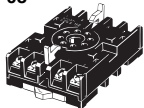
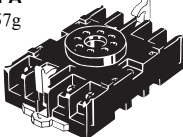
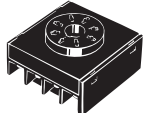

*2 不是耐助焊剂构造。为手动焊接推荐产品。

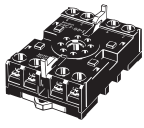
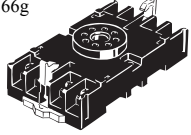
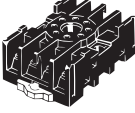
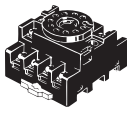
形状 插脚数	P7LF (表面连接) 第16页
6脚	P7LF-06 约60g 

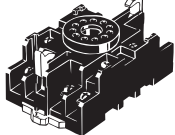
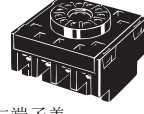
注: 共用插座标准认证机型的详情请参见“标准认证机型一览表”。

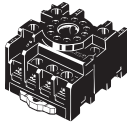
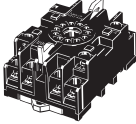
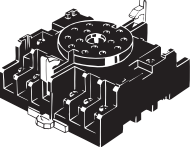

● 圆形插座

形状 插脚数	PF (表面连接) 第16页	P2CF (表面连接) 第18页	PFA (表面连接) 第19页	P3G (背面连接) 第20页	PL (背面连接) 第21页		
					焊接端子	研磨端子	印刷电路板 用端子
8脚	PF083A 约34g 	P2CF-08 约55g 	8PFA 约57g 	P3G-08 约40g  注：与端子盖 (Y92A-48G) 组合使用，可实现指触保护。	PL08 约14g 	PL08-Q 约15g 	PLE08-0 约10.6g 
	PF083A-E * 	P2CF-08-E 	8PFA1 约66g 				
	PF085A 约40g 						
11脚	PF113A 约47g 	P2CF-11 约70g 	11PFA 约74g 	P3GA-11 约47g  注：与端子盖 (Y92A-48G) 组合使用，可实现指触保护。	PL11 约15g 	PL11-Q 约18.5g 	PLE11-0 约10.8g 
	PF113A-E * 	P2CF-11-E 					
14脚	—	—	14PFA 约104g 	—	PL15 约28g 	—	—
20脚	—	—	—	—	PL20 约17g 	—	—

注：-E型为指触保护结构。不能使用圆形端子。请使用Y形端子等。
* 本产品螺钉的紧固，请使用1号螺丝刀。

● 端子盖

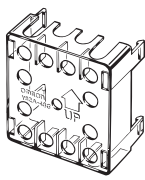
型号	Y92A-48G
形状	

注：共用插座标准认证机型的详情请参见“标准认证机型一览表”。



■固定支架

(单位: mm)

● 方形插座用

<p>PHC-12</p>	<p>PKC 1套 (2个)</p>	<p>PTC-1</p>	<p>PYC-A1 约0.54g 1套 (2个)</p>	<p>PYC-A2 1套 (2个)</p>	<p>PYC-E1 1套 (2个)</p>
<p>PYC-P 约1.4g</p>	<p>PYC-P2 约1.2g</p>	<p>PYC-S 约1.8g</p>	<p>PYC-1 约6g</p>	<p>PYC-2</p>	<p>PYC-3</p>
<p>PYC-5</p>	<p>PYC 约0.2g</p>	<p>Y92H-1</p>	<p>Y92H-3 1套 (2个)</p>	<p>Y92H-4</p>	

● 圆形插座用

<p>PFC-A1 约2.2g 1套 (2个)</p>	<p>PFC-A6 约2.4g 1套 (2个)</p>	<p>PFC-A7 约3.0g 1套 (2个)</p>	<p>PLC 约2.4g 1套 (2个)</p>	<p>PLC-1 约2.6g 1套 (2个)</p>	<p>PLC-7 约3.0g 1套 (2个)</p>
<p>PLC-8 约6.4g 1套 (2个)</p>	<p>PLC-10 约2.0g 1套 (2个)</p>	<p>PLC-12 约5.4g 1套 (2个)</p>			



■固定支架适用机型

● 方形插座用

插座 适用机型	PYF□A PTF□A	PYF08M	PY□ (QN) PT□ (QN)	PY□-02 PT□-0		
MY□、MY□N MY□-D MY2□-CR MY4□-CR MY4Z□-CR MY□-TU MY2K MY□N-D2 LY□、LY□N LY□-TU MYG□ G3H (D) 系列 G3F (D) 系列 G3FM G9H	PYC-A1	PYC PYC-P	PYC-P PYC-S	PYC-P		
MY□I * LY□I					—	PYC-P2
MY4H					—	PYC-P
MY2Z□-CR MY3□-CR LY□-CR	Y92H-3	—	PYC-1			
G2A (K) 系列	PYC-A2	—	PYC-2 PYC-3 PYC-5	PYC-3 PYC-5		
G7K	PKC	—				
H3Y	Y92H-3	—	Y92H-4			

注：插座型号的□内为08、11、14。

* MY2I使用固定支架时，无法使用PYF08A。

请使用PYF14A。

● 圆形插座用

插座 适用机型	PF083A PF113A	PL08 (-Q) PL11 (-Q)	PLE08-0 PLE11-0	P2CF-11
61F-03B、-04B	PFC-A1	PLC	PLC-10	—
61F-GP-N、-GPN-BT 61F-GP-N8 61F-APN2	PFC-N8	PHC-5		
MK2P系列 MK2KP MK3P□ (-US) G3B (D) 系列	PFC-A1	PLC		
MK3ZP MK3LP		PLC-1		
MYA-NA1、-NB1 MYA-LA1、-LB1 MYA-NA2、-NB2 MYA-LA2、-LB2	PFC-A6	PLC-7	—	—
MYA-LA12、-LB12	PFC-A7	PLC-8	—	—
APR-S	PFC-A6	PLC-7	—	—
APR-S380/-S440	—	—	—	Y92H-1
LG2	PFC-A7	PLC-8	—	—
K6EL	—	Y92H-1	—	—

注1. 8PFA(1)、11PFA、14PFA为挂钩支承方式。

2. PL15、PL20、PF202及上表的适用机型中未刊载的机型为面板加工安装。

3. H3M、H2A适用机型均附带PF085A的固定支架。H2C适用机型为选装件（另售）。



规格

■插座特性

型号	连续通电电流	耐电压	绝缘电阻*	备注
P2RF-05 (-E)	10A	同极接点端子间 : AC1,000V 1min	1,000MΩ以上	
		线圈接点端子间 : AC4,000V 1min		
P2RF-08 (-E)	5A	异极接点端子间 : AC3,000V 1min	1,000MΩ以上	
		同极接点端子间 : AC1,000V 1min		
		线圈接点端子间 : AC4,000V 1min		
P2R-05P	10A	同极接点端子间 : AC1,000V 1min	1,000MΩ以上	
		线圈接点端子间 : AC4,000V 1min		
P2R-08P	5A	异极接点端子间 : AC3,000V 1min	1,000MΩ以上	
		同极接点端子间 : AC1,000V 1min		
		线圈接点端子间 : AC4,000V 1min		
P2R-057P	10A	同极接点端子间 : AC1,000V 1min	1,000MΩ以上	
		线圈接点端子间 : AC5,000V 1min		
P2R-087P	5A	异极接点端子间 : AC3,000V 1min	1,000MΩ以上	
		同极接点端子间 : AC1,000V 1min		
		线圈接点端子间 : AC5,000V 1min		
P2R-05A	10A	同极接点端子间 : AC1,000V 1min	1,000MΩ以上	
		接地端子间 : AC1,500V 1min		
		线圈接点端子间 : AC4,000V 1min		
P2R-08A	5A	异极接点端子间 : AC3,000V 1min	1,000MΩ以上	
		同极接点端子间 : AC1,000V 1min		
		接地端子间 : AC1,500V 1min		
		线圈接点端子间 : AC4,000V 1min		
P7TF-05	5A	端子间 : AC2,000V 1min	1,000MΩ以上	
PYF08A (-E)	7A	端子间 : AC2,000V 1min	1,000MΩ以上	PYF08S的连续通电电流10A为环境温度最高为55°C时的值。环境温度70°C时为7A。
PYF11A	5A	端子间 : AC2,000V 1min	1,000MΩ以上	
PYF14A (-E)	3A	端子间 : AC2,000V 1min	1,000MΩ以上	
PY08 (-Y1) (-Y3)	7A	端子间 : AC1,500V 1min	1,000MΩ以上	
PY08QN (-Y1)	7A	端子间 : AC1,500V 1min	100MΩ以上	
PY08-02	7A	端子间 : AC1,500V 1min	100MΩ以上	
PY11 (-Y1)	5A	端子间 : AC1,500V 1min	100MΩ以上	
PY11QN (-Y1)	5A	端子间 : AC1,500V 1min	100MΩ以上	
PY11-02	5A	端子间 : AC1,500V 1min	100MΩ以上	
PY14 (-Y1) (-Y3)	3A	端子间 : AC1,500V 1min	100MΩ以上	
PY14QN (-Y1)	3A	端子间 : AC1,500V 1min	100MΩ以上	
PY14-02	3A	端子间 : AC1,500V 1min	100MΩ以上	
PTF□□A (-E)	10A	端子间 : AC2,000V 1min	100MΩ以上	
PT□□	10A	端子间 : AC2,000V 1min	100MΩ以上	
PT□□QN	10A	端子间 : AC2,000V 1min	100MΩ以上	
PT□□-0	10A	端子间 : AC2,000V 1min	100MΩ以上	
P7LF-06	30A	异极接点端子间 : AC2,000V 1min	1,000MΩ以上	
		同极接点端子间 : AC2,000V 1min		
		线圈接点端子间 : AC4,000V 1min		
PF□□□A (-E)	5A	端子间 : AC2,000V 1min	1,000MΩ以上	
P2CF-□ (-E)	5A	端子间 : AC2,000V 1min	1,000MΩ以上	
8PFA (1)	10A	端子间 : AC2,000V 1min	1,000MΩ以上	
11PFA (1)	10A	端子间 : AC2,000V 1min	1,000MΩ以上	
P3G (A) -□	6A	端子间 : AC2,000V 1min	1,000MΩ以上	
PL□□ (-Q)	10A	端子间 : AC2,000V 1min	1,000MΩ以上	
PLE□□-0	10A	端子间 : AC2,000V 1min	1,000MΩ以上	

* 用DC500V绝缘电阻计测量与耐电压项目中相同的部位。

■注意事项

共通注意事项请参见“继电器共通注意事项”。



外形尺寸

■P2RF

(单位: mm)

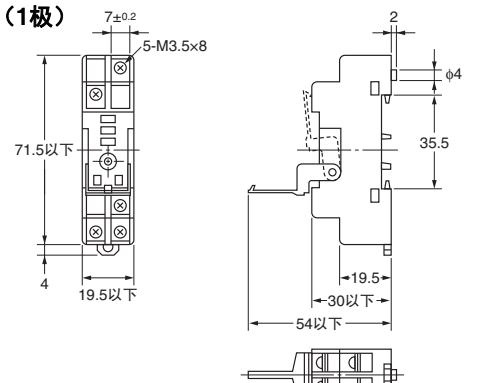
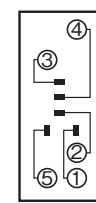
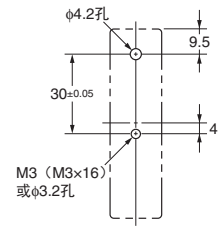
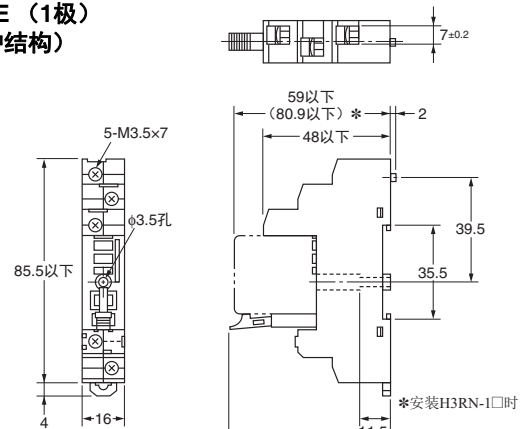
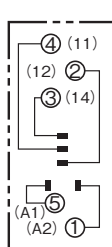
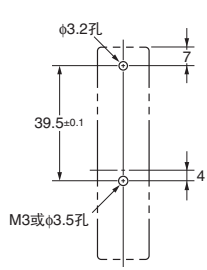
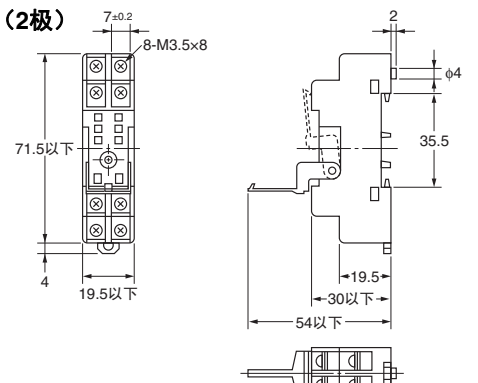
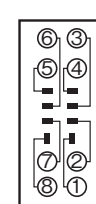
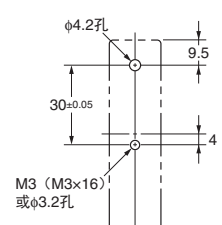
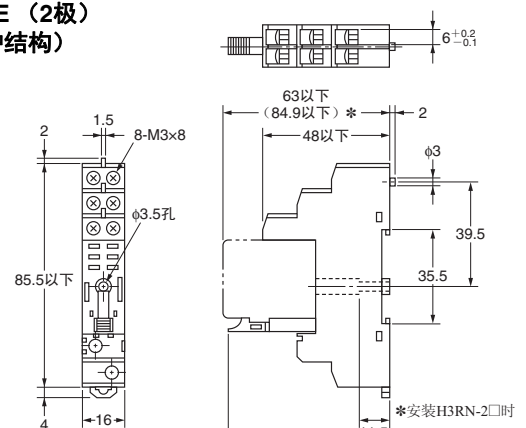
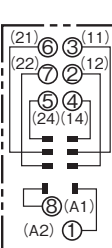
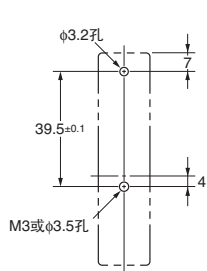





外形尺寸	端子配置/内部连接	安装孔加工尺寸
<p>P2RF-05 (1极)</p> 	 <p>(顶视图)</p>	 <p>(顶视图)</p> <p>注: 也可进行导轨安装。</p>
<p>P2RF-05-E (1极) (指触保护结构)</p> 	 <p>(顶视图)</p> <p>注: () 内的数字为DIN标准的编号。</p>	 <p>(顶视图)</p> <p>注: 也可进行导轨安装。</p>
<p>P2RF-08 (2极)</p> 	 <p>(顶视图)</p>	 <p>(顶视图)</p> <p>注: 也可进行导轨安装。</p>
<p>P2RF-08-E (2极) (指触保护结构)</p> 	 <p>(顶视图)</p> <p>注: () 内的数字为DIN标准的编号。</p>	 <p>(顶视图)</p> <p>注: 也可进行导轨安装。</p>

注: 使用I/O SSR、指示灯模块时①端子为⊖极性, 敬请注意。

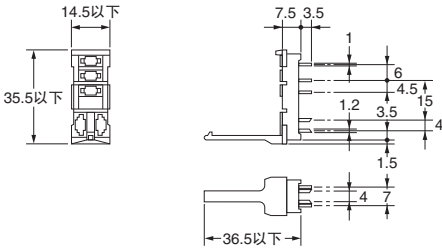

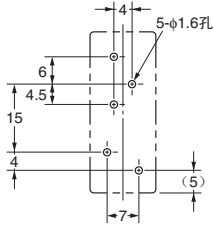
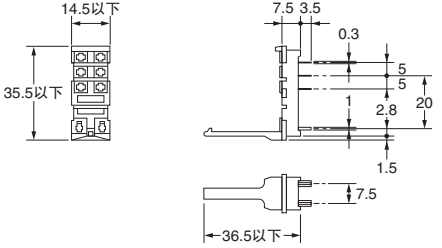
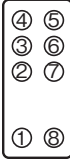
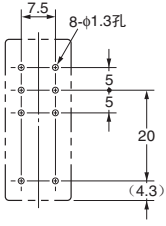
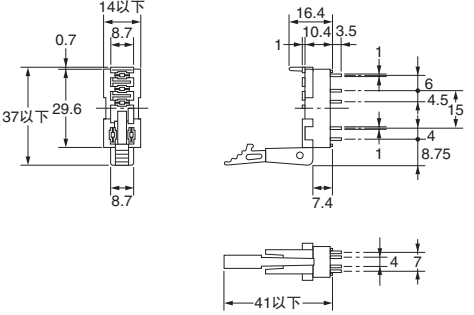
■P2R

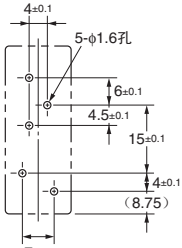
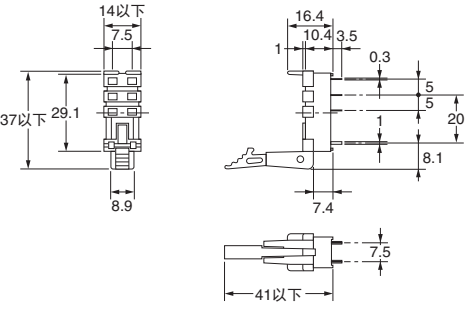
(单位: mm)

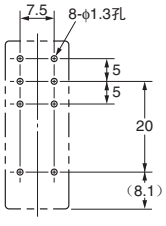
外形尺寸	端子配置/内部连接	印刷电路板加工尺寸
<p>P2R-05P (1极)</p> 	 <p>(底视图)</p>	 <p>(底视图)</p>
<p>P2R-08P (2极)</p> 	 <p>(底视图)</p>	 <p>(底视图)</p>
<p>P2R-057P (1极)</p> 	 <p>(底视图)</p>	 <p>(底视图)</p>
<p>P2R-087P (2极)</p> 	 <p>(底视图)</p>	 <p>(底视图)</p>

注: 使用I/O SSR、指示灯模块时①端子为⊖极性, 敬请注意。

■P2R

(单位: mm)

外形尺寸	端子配置/内部连接	安装孔加工尺寸
<p>P2R-05A (1极)</p>	<p>(底视图)</p>	<p>(面板的厚度请使用1.6~2.0mm。)</p>
<p>P2R-08A (2极)</p>	<p>(底视图)</p>	

注: 使用I/O SSR、指示灯模块时①端子为⊖极性, 敬请注意。

■P7TF

(单位: mm)

外形尺寸	端子配置/内部连接	安装孔加工尺寸
<p>P7TF-05</p>	<p>(顶视图)</p>	<p>(顶视图)</p> <p>注: 也可进行导轨安装。 * 使用M3安装时, 建议组装垫圈。 使用M4安装时, 无需使用垫圈。</p>

注: 使用I/O SSR、指示灯模块时①端子为⊕极性, 敬请注意。

■PYF

(单位: mm)

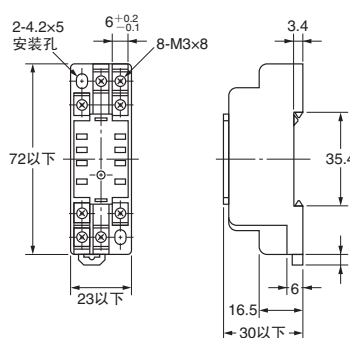
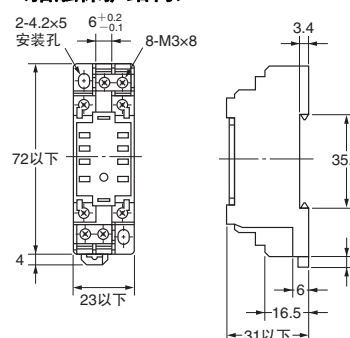
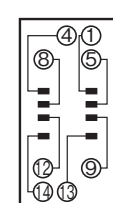
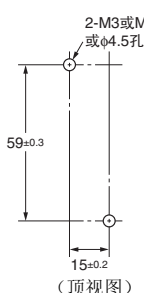
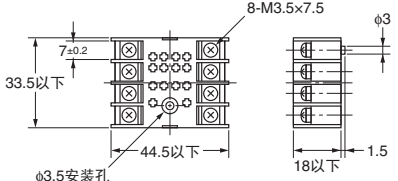
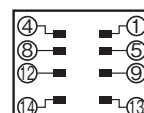
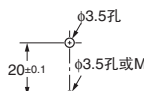
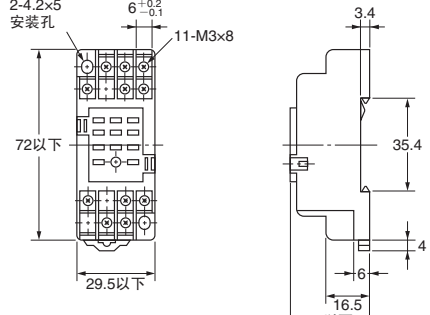
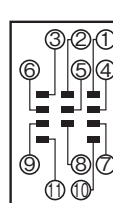
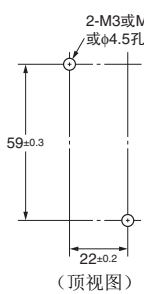
外形尺寸	端子配置/内部连接	安装孔加工尺寸
<p>PYF08A</p>  <p>PYF08A-E (指触保护结构)</p> 	 <p>(顶视图)</p>	 <p>注: 也可进行导轨安装。</p>
<p>PYF08M</p>  <p>φ3.5安装孔 φ6.5 铆孔 深11.5</p>	 <p>(顶视图)</p>	
<p>PYF11A</p> 	 <p>(顶视图)</p>	 <p>注: 也可进行导轨安装。</p>

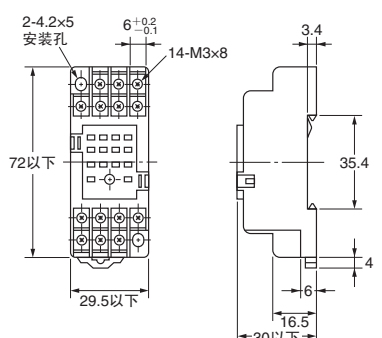
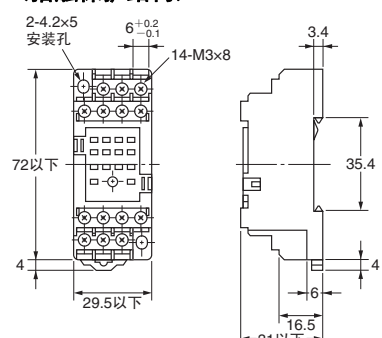
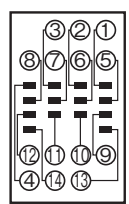
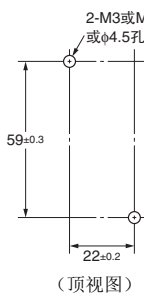

PYF

(单位: mm)

外形尺寸		端子配置/内部连接	安装孔加工尺寸
<p>PYF14A</p> 	<p>PYF14A-E (指触保护结构)</p> 	 <p>(顶视图)</p>	 <p>(顶视图)</p> <p>注: 也可进行导轨安装。 请参见第25页。</p>



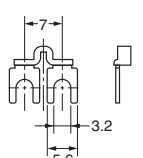

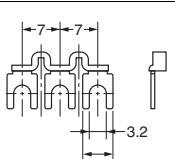
● 继电器插座/PYF用短路棒

同一插座内的跨接

间距	适用机型	形状	外形尺寸 (mm)	型号	规格
7mm	PYF14A			PYD-020B□ (2P)	最大通电电流 : 20A (70°C时为18A) 使用环境温度 : -40~+70°C (无结冰、结露) 使用环境湿度 : 45~85%RH (无结冰、结露) 导电部材质 : 黄铜 导电部表面处理: 镀镍 包装单位 : 50个/袋
				PYD-030B□ (3P)	

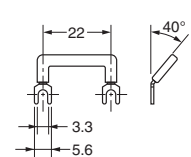
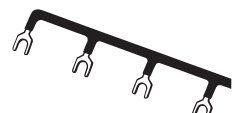
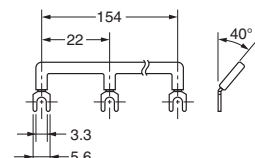
注: 型号的口内为包层颜色的指定符号。B (黑色)、Y (黄色)

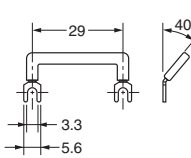
相邻插座间的跨接

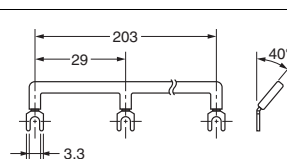

间距	适用机型	形状	外形尺寸 (mm)	型号	规格
22mm	PYF08A			PYD-025B□ (2P)	最大通电电流 : 20A (70°C时为18A) 使用环境温度 : -40~+70°C (无结冰、结露) 使用环境湿度 : 45~85%RH (无结冰、结露) 导电部材质 : 黄铜 导电部表面处理: 镀镍 包装单位 : 10个/袋
				PYD-085B□ (8P)	
29mm	PYF14A			PYD-026B□ (2P)	最大通电电流 : 20A (70°C时为18A) 使用环境温度 : -40~+70°C (无结冰、结露) 使用环境湿度 : 45~85%RH (无结冰、结露) 导电部材质 : 黄铜 导电部表面处理: 镀镍 包装单位 : 10个/袋
				PYD-086B□ (8P)	

注: 型号的口内为包层颜色的指定符号。B (黑色)、S (蓝色)、R (红色)

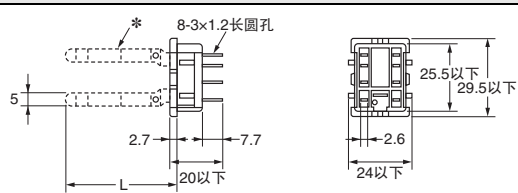
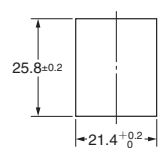
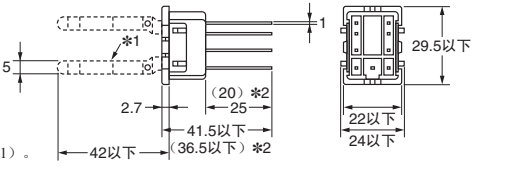
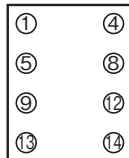
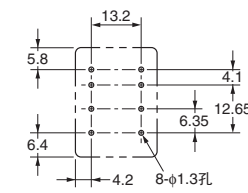
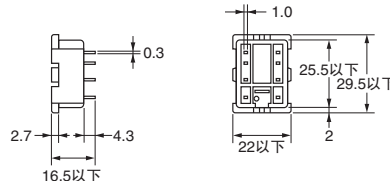
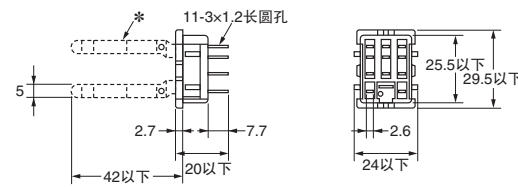
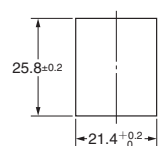
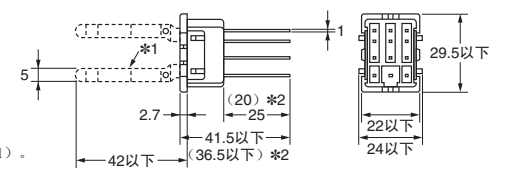

■PY

(单位: mm)

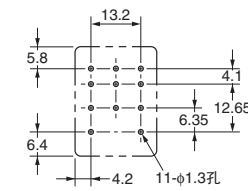
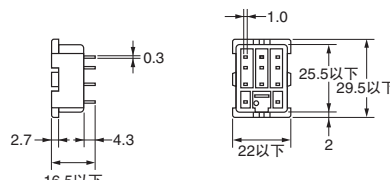
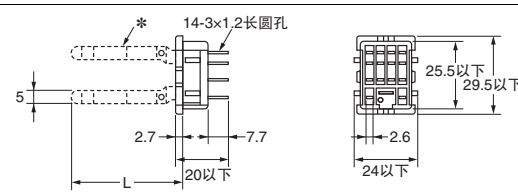
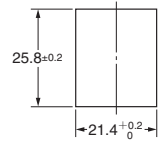
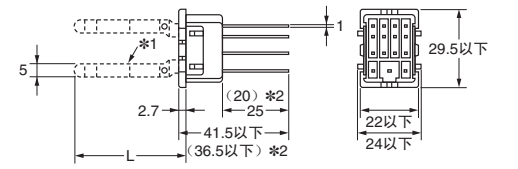
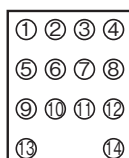
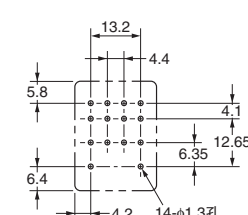
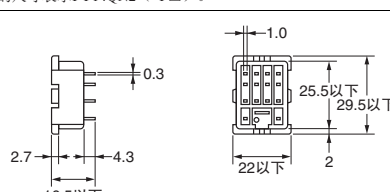
外形尺寸	端子配置/内部连接	安装孔及印刷电路板加工尺寸
<p>PY08 PY08-Y1 (L=42以下) PY08-Y3 (L=60以下)</p>  <p>*PY08-Y时包括虚线部。</p>		
<p>PY08QN PY08QN2 PY08QN-Y1 PY08QN2-Y1</p>  <p>*1. PY08QN (2) -Y1时包括虚线部。 *2. () 内的尺寸表示PY08QN2 (-Y1)。</p>	 <p>(底视图)</p>	
<p>PY08-02</p> <p>• 不是耐助焊剂构造。 为手动焊接推荐产品。</p> 		
<p>PY11 PY11-Y1</p>  <p>*PY11-Y1时包含虚线部。</p>		
<p>PY11QN PY11QN2 PY11QN-Y1 PY11QN2-Y1</p>  <p>*1. PY11QN (2) -Y1时包含虚线部。 *2. () 内的尺寸表示PY11QN2 (-Y1)。</p>	 <p>(底视图)</p>	
<p>PY11-02</p> <p>• 不是耐助焊剂构造。 为手动焊接推荐产品。</p> 		
<p>PY14 PY14-Y1 (L=42以下) PY14-Y3 (L=60以下)</p>  <p>*PY14-Y□时包含虚线部。</p>		
<p>PY14QN PY14QN2 PY14QN-Y1 (L=42以下) PY14QN2-Y1 (L=42以下) PY14QN-Y3 (L=60以下) PY14QN2-Y3 (L=60以下)</p>  <p>*1. PY14QN-Y□、PY14QN2-Y□时包含虚线部。 *2. () 内的尺寸表示PY14QN2 (-Y□)。</p>	 <p>(底视图)</p>	
<p>PY14-02</p> <p>• 不是耐助焊剂构造。 为手动焊接推荐产品。</p> 		

注1. 插座的安装面板请使用板厚1~2mm。
 2. PY14-Y1及PY14QN-Y1可适用于MY4系列、MY4H、MYQ4 (Z)、MY2K。
 3. PY14-Y3及PY14QN-Y3可适用于H3Y (定时器)。



PTF

(单位: mm)

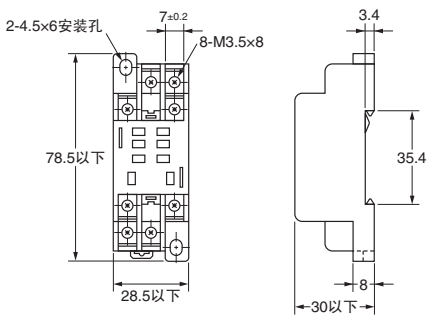
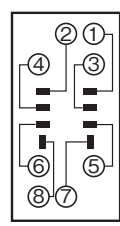
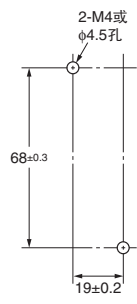
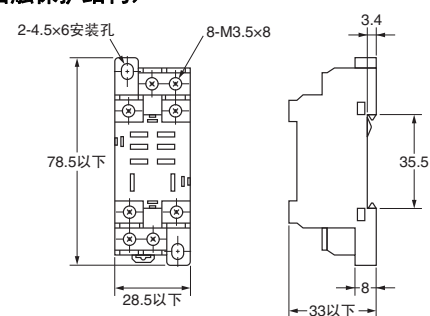
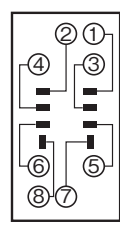
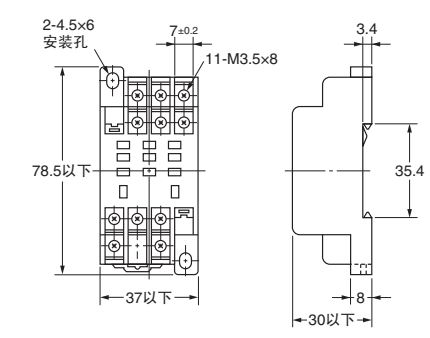
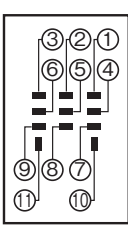
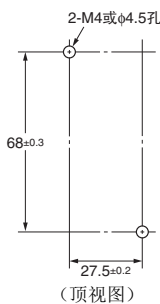
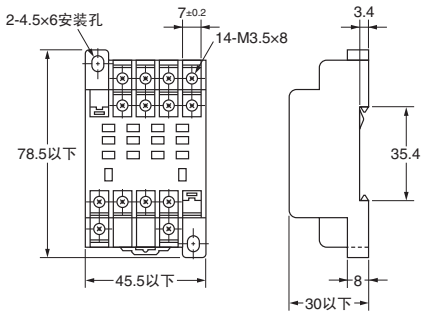
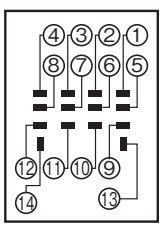
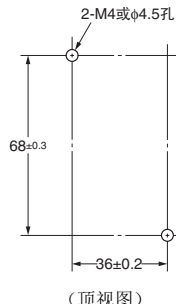
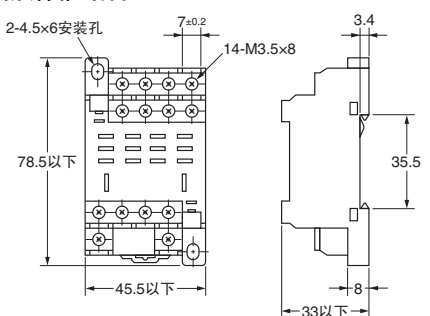
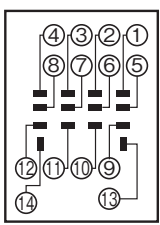
外形尺寸	端子配置/内部连接	安装孔加工尺寸
<p>PTF08A</p> 	 <p>(顶视图)</p>	 <p>(顶视图)</p>
<p>PTF08A-E (指触保护结构)</p> 	 <p>(顶视图)</p>	<p>注: 也可进行导轨安装。</p>
<p>PTF11A</p> 	 <p>(顶视图)</p>	 <p>(顶视图)</p> <p>注: 也可进行导轨安装。</p>
<p>PTF14A</p> 	 <p>(顶视图)</p>	 <p>(顶视图)</p> <p>注: 也可进行导轨安装。</p>
<p>PTF14A-E (指触保护结构)</p> 	 <p>(顶视图)</p>	<p>注: 也可进行导轨安装。</p>

注: PTF08A、PTF08A-E、PT08和LY1的继电器组合使用时，请分别使端子No.①-②间、③-④间、⑤-⑥间短路。(使用电流为10A以上时)



■PT

(单位: mm)

外形尺寸		端子配置/内部连接	安装孔及印刷电路板加工尺寸
PT08 	PT08QN 	<p>(底视图)</p>	
PT08-0 <p>* 使用双面电路板时, 请注意与电路板间的距离。 · 不是耐助焊剂构造。 · 为手动焊接推荐产品。</p>			<p>尺寸公差为±0.1。</p>
PT11 	PT11QN 	<p>(底视图)</p>	
PT11-0 <p>* 使用双面电路板时, 请注意与电路板间的距离。 · 不是耐助焊剂构造。 · 为手动焊接推荐产品。</p>			<p>尺寸公差为±0.1。</p>
PT14 	PT14QN 	<p>(底视图)</p>	
PT14-0 <p>* 使用双面电路板时, 请注意与电路板间的距离。 · 不是耐助焊剂构造。 · 为手动焊接推荐产品。</p>			<p>尺寸公差为±0.1。</p>

注: 插座的安装面板请使用板厚1~2mm。



■P7LF

(单位: mm)

外形尺寸	端子配置/内部连接	安装孔加工尺寸
<p>P7LF-06</p> <p>2-M3.5x6 (线圈侧)</p> <p>8±0.05</p> <p>4-M4x8 (接点侧)</p> <p>40±0.1</p> <p>55.5以下</p> <p>9.2±0.05</p> <p>25</p> <p>46以下</p> <p>51.5以下</p> <p>5</p>	<p>(顶视图)</p>	<p>2-M4或φ4.5孔</p> <p>40±0.1</p>

■PF

(单位: mm)

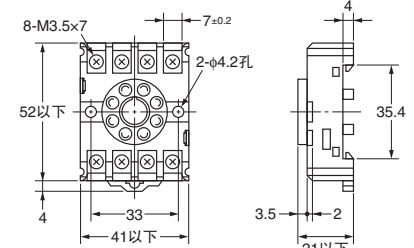
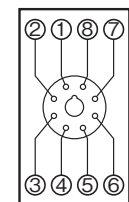
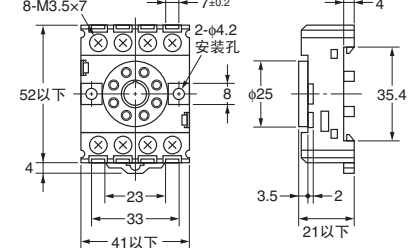
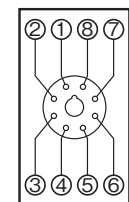
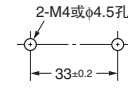
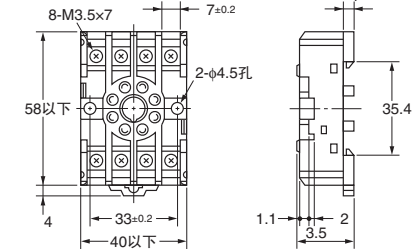
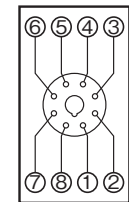
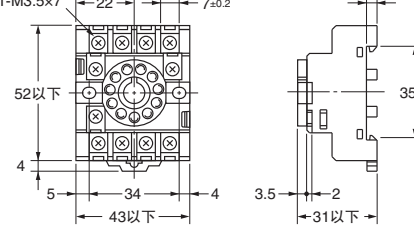
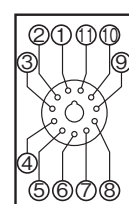
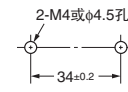
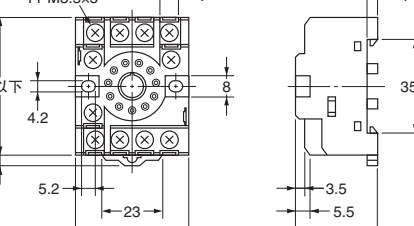
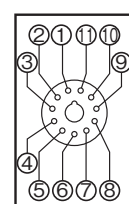
外形尺寸	端子配置/内部连接	安装孔加工尺寸
<p>PF083A</p> 	 <p>(顶视图)</p>	
<p>PF083A-E</p> 	 <p>(顶视图)</p>	 <p>注: 也可进行导轨安装。</p>
<p>PF085A</p> 	 <p>(顶视图)</p>	
<p>PF113A</p> 	 <p>(顶视图)</p>	 <p>注: 也可进行导轨安装。</p>
<p>PF113A-E</p> 	 <p>(顶视图)</p>	<p>注: 也可进行导轨安装。</p>

注1. PF083A、PF113A插座的键槽位于上侧。(适用机型 MK)

2. -E型为指触保护结构。不能使用圆形端子。请使用Y形端子等。



■P2CF

(单位: mm)

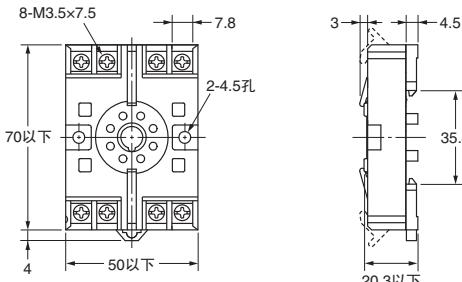
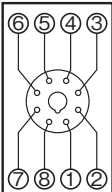
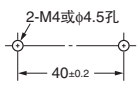
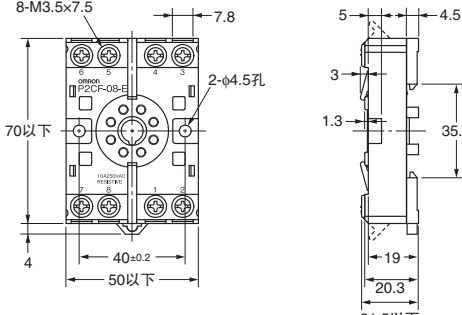
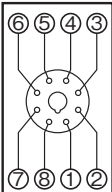
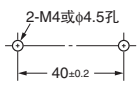
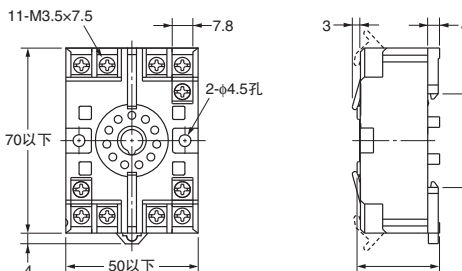
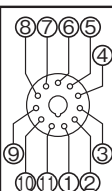
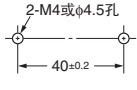
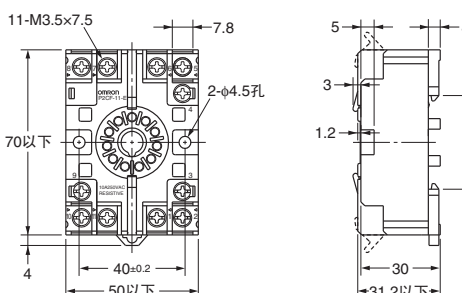
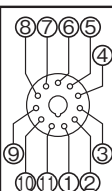
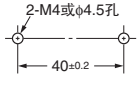
外形尺寸	端子配置/内部连接	安装孔加工尺寸
<p>P2CF-08</p> 	 <p>(顶视图)</p>	 <p>注: 也可进行导轨安装。</p>
<p>P2CF-08-E</p> 	 <p>(顶视图)</p>	 <p>注: 也可进行导轨安装。</p>
<p>P2CF-11</p> 	 <p>(顶视图)</p>	 <p>注: 也可进行导轨安装。</p>
<p>P2CF-11-E</p> 	 <p>(顶视图)</p>	 <p>注: 也可进行导轨安装。</p>

■PFA

(单位: mm)

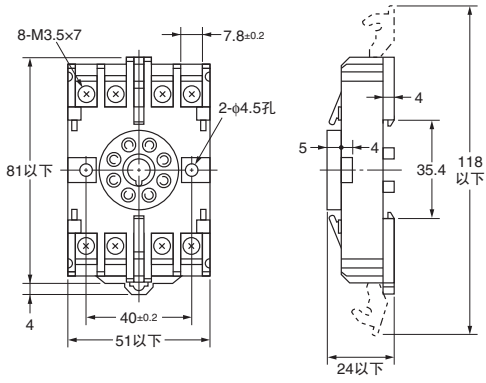
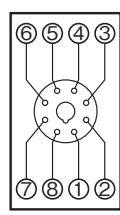
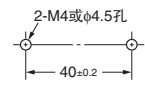
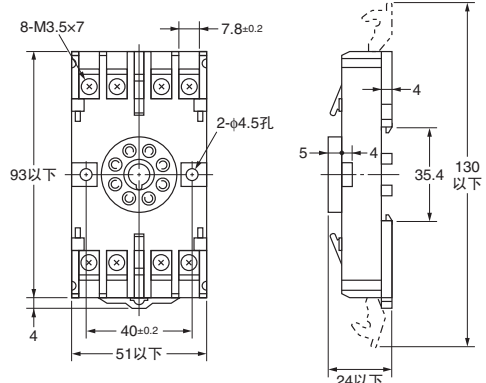
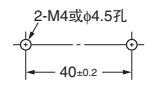
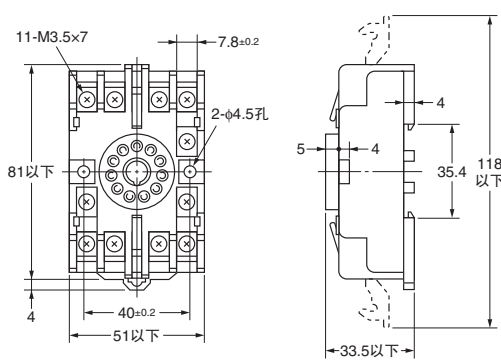
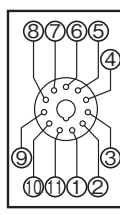
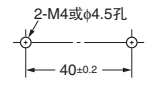
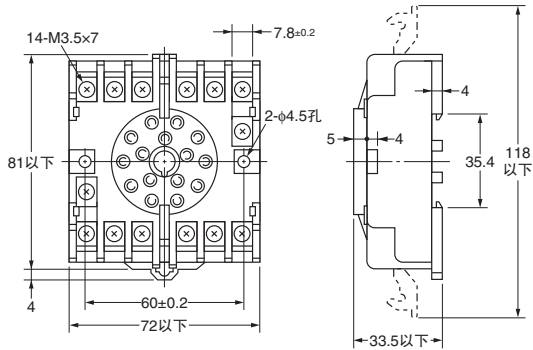
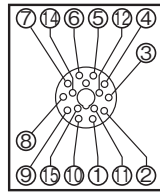
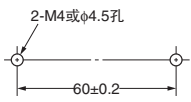
外形尺寸	端子配置/内部连接	安装孔加工尺寸
<p>8PFA</p> 	 <p>(顶视图)</p>	 <p>注: 也可进行导轨安装。</p>
<p>8PFA1</p> 	<p>(顶视图)</p>	 <p>注: 也可进行导轨安装。</p>
<p>11PFA</p> 	 <p>(顶视图)</p>	 <p>注: 也可进行导轨安装。</p>
<p>14PFA</p> 	 <p>(顶视图)</p>	 <p>注: 也可进行导轨安装。</p>

■P3G/P3GA

(单位: mm)

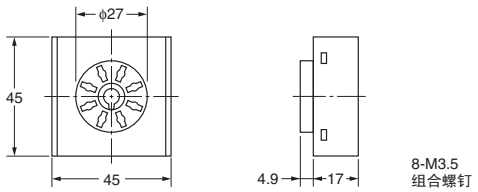
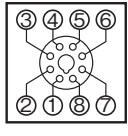
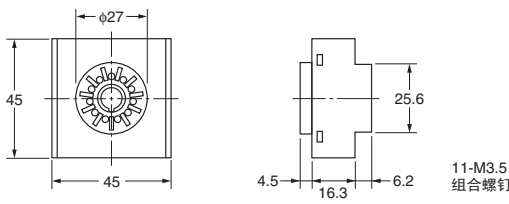
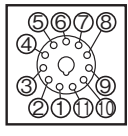
外形尺寸	端子配置/内部连接	安装孔加工尺寸
<p>P3G-08</p>  <p>注: 与端子盖 (Y92A-48G) 组合使用, 可实现指触保护。</p>	 <p>(底视图)</p>	—
<p>P3GA-11</p>  <p>注: 与端子盖 (Y92A-48G) 组合使用, 可实现指触保护。</p>	 <p>(底视图)</p>	—

■端子盖

(单位: mm)

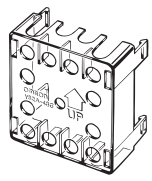
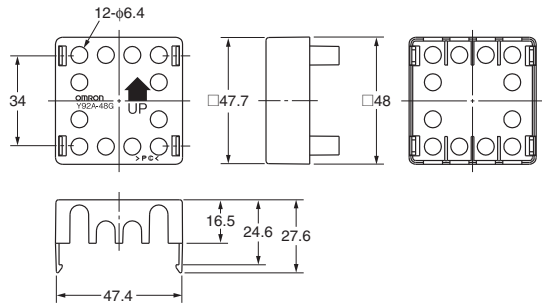
形状	外形尺寸
	<p>Y92A-48G</p> 

PL

(单位: mm)

外形尺寸	端子配置/内部连接	安装孔及印刷电路板加工尺寸 (底视图)
PL08 		2-φ3.5或2-M3 适用机型安装孔 L=40mm MK2 (Z) P L=74mm PU、AMD-S MM2 (X) P、CZ STP、H3L、TDS、DTS DSP、TDF、TDV L=86mm 61F-GP/-APN、G4Q-212S RD2P、RDA、TDA、AGF、 SE、SAD、K2CU、SDV-F
PL08-Q 	(底视图)	2-φ3.5或2-M3 插座安装孔 MK2 (Z) P
PLE08-0 		2-φ3.5孔 固定支架安装孔 MK2 (Z) P
PL11 		2-φ3.5或2-M3 适用机型/ 固定支架安装孔 L=40mm MK3P MK2KP L=74mm MM3P MK2 (X) KP 2-φ3.5或2-M3 插座安装孔
PL11-Q 	(底视图)	L=42mm MK3ZP MK3LP
PLE11-0 		2-φ3.5孔 适用机型/固定支架安装孔 L=40mm MK3P MK2KP L=42mm MK3ZP MK3LP
PL15 	(底视图)	2-φ3.5或2-M3 适用机型安装孔 L=74mm MM3XP MM4 (X) P MM3 (X) KP MM4 (X) KP 2-φ3.5或2-M3 插座安装孔
PL20 	(底视图)	2-φ4.5 继电器安装孔 2-φ4 插座安装孔 * LDNP无需继电器安装孔加工。

注: 安装时请注意适用机型的键槽方向。



承诺事项

承蒙对欧姆龙株式会社(以下简称“本公司”)产品的一贯厚爱和支持, 藉此机会再次深表谢意。
如果未特别约定, 无论贵司从何处购买的产品, 都将适用本承诺事项中记载的事项。
请在充分了解这些注意事项基础上订购。

1. 定义

本承诺事项中的术语定义如下。

- (1) “本公司产品”: 是指“本公司”的FA系统机器、通用控制器、传感器、电子/结构部件。
- (2) “产品目录等”: 是指与“本公司产品”有关的欧姆龙综合产品目录、FA系统设备综合产品目录、安全组件综合产品目录、电子/机构部件综合产品目录以及其他产品目录、规格书、使用说明书、操作指南等, 包括以电子数据方式提供的资料。
- (3) “使用条件等”: 是指在“产品目录等”资料中记载的“本公司产品”的使用条件、额定值、性能、运行环境、操作使用方法、使用时的注意事项、禁止事项以及其他事项。
- (4) “客户用途”: 是指客户使用“本公司产品”的方法, 包括将“本公司产品”组装或运用到客户生产的部件、电子电路板、机器、设备或系统等产品中。
- (5) “适用性等”: 是指在“客户用途”中“本公司产品”的(a)适用性、(b)动作、(c)不侵害第三方知识产权、(d)法规法令的遵守以及(e)满足各种规格标准。

2. 关于记载事项的注意事项

对“产品目录等”中的记载内容, 请理解如下要点。

- (1) 额定值及性能值是在单项试验中分别在各条件下获得的值, 并不构成对各额定值及性能值的综合条件下获得值的承诺。
- (2) 提供的参考数据仅作为参考, 并非可在该范围内一直正常运行的保证。
- (3) 应用示例仅作参考, 不构成对“适用性等”的保证。
- (4) 如果因技术改进等原因, “本公司”可能会停止“本公司产品”的生产或变更“本公司产品”的规格。

3. 使用时的注意事项

选用及使用本公司产品时请理解如下要点。

- (1) 除了额定值、性能指标外, 使用时还必须遵守“使用条件等”。
- (2) 客户应事先确认“适用性等”, 进而再判断是否选用“本公司产品”。“本公司”对“适用性等”不做任何保证。
- (3) 对于“本公司产品”在客户的整个系统中的设计用途, 客户应负责事先确认是否已进行了适当配电、安装等事项。
- (4) 使用“本公司产品”时, 客户必须采取如下措施: (i) 相对额定值及性能指标, 必须在留有余量的前提下使用“本公司产品”, 并采用冗余设计等安全设计(ii)所采用的安全设计必须确保即使“本公司产品”发生故障时也可将“客户用途”中的危险降到最小程度、(iii)构建随时提示使用者危险的完整安全体系、(iv)针对“本公司产品”及“客户用途”定期实施各项维护保养。
- (5) “本公司产品”是作为应用于一般工业产品的通用产品而设计生产的。如果客户将“本公司产品”用于以下所列用途, 则本公司对产品不作任何保证。但“本公司”已表明可用于特殊用途, 或已与客户有特殊约定时, 另行处理。
 - (a) 必须具备很高安全性的用途(例: 核能控制设备、燃烧设备、航空/宇宙设备、铁路设备、升降设备、娱乐设备、医疗设备、安全装置、其他可能危及生命及人身安全的用途)
 - (b) 必须具备很高可靠性的用途(例: 燃气、自来水、电力等供应系统、24小时连续运行系统、结算系统、以及其他处理权利、财产的用途等)
 - (c) 具有苛刻条件或严酷环境的用途(例: 安装在室外的设备、会受到化学污染的设备、会受到电磁波影响的设备、会受到振动或冲击的设备等)
 - (d) “产品目录等”资料中未记载的条件或环境下的用途
- (6) 除了不适用于上述3.(5)(a)至(d)中记载的用途外, “本产品目录等资料中记载的产品”也不适用于汽车(含二轮车, 以下同)。请勿配置到汽车上使用。关于汽车配置用产品, 请咨询本公司销售人员。

4. 保修条件

“本公司产品”的保修条件如下。

- (1) 保修期限 自购买之日起1年。(但是, “产品目录等”资料中有明确说明时除外。)
- (2) 保修内容 对于发生故障的“本公司产品”, 由“本公司”判断并可选择以下其中之一方式进行保修。
 - (a) 在本公司的维修保养服务点对发生故障的“本公司产品”进行免费修理(但是对于电子、结构部件不提供修理服务。)
 - (b) 对发生故障的“本公司产品”免费提供同等数量的替代品
- (3) 当故障因以下任何一种情形引起时, 不属于保修的范围。
 - (a) 将“本公司产品”用于原本设计用途以外的用途
 - (b) 超过“使用条件等”范围的使用
 - (c) 违反本注意事项“3. 使用时的注意事项”的使用
 - (d) 非因“本公司”进行的改装、修理导致故障时
 - (e) 非因“本公司”出品的软件导致故障时
 - (f) “本公司”生产时的科学、技术水平无法预见的原因
 - (g) 除上述情形外的其它原因, 如“本公司”或“本公司产品”以外的原因(包括天灾等不可抗力)

5. 责任限制

本承诺事项中记载的保修是关于“本公司产品”的全部保证。对于因“本公司产品”而发生的其他损害, “本公司”及“本公司产品”的经销商不负任何责任。

6. 出口管理

客户若将“本公司产品”或技术资料出口或向境外提供时, 请遵守中国及各国关于安全保障进出口管理方面的法律、法规。否则, “本公司”有权不予提供“本公司产品”或技术资料。

IC310GC-zh

2018.7

注: 规格如有变更, 恕不另行通知。请以最新产品说明书为准。

欧姆龙自动化(中国)有限公司

http://www.fa.omron.com.cn/ 咨询热线: 400-820-4535

欧姆龙自动化(中国)有限公司 版权所有 2018