



# Technical Data Sheet

## 3.0mm Multi-Color Round Type LED Lamps

209SURSYGW/S530-A3

### ■ Features :

- Two chips are matched for uniform light output, wide viewing angle
- Long life-solid state reliability
- I.C. compatible/Low power consumption
- Pb free
- The product itself will remain within RoHS compliant version



### ■ Descriptions :

- The 269-7LED lamps contain two integral chips and is available as both bicolor and bipolar types.
- Hyper Red and Super Yellow Green light is emitted by diodes of AlGaInP and AlGaInP
- Type of bicolor lamps are both white diffused and color diffused while the bicolor are water clear.

### ■ Applications :

- TV set
- Monitor
- Telephone
- Computer

PART NO.	Chip		Lens Color
	Material	Emitted Color	
209SURSYGW/S530-A3	AlGaInP	Hyper Red	White Diffused
	AlGaInP	Super Yellow Green	



Technical Data Sheet  
3.0mm Multi-Color Round Type LED Lamps

209SURSYGW/S530-A3

Package Dimensions

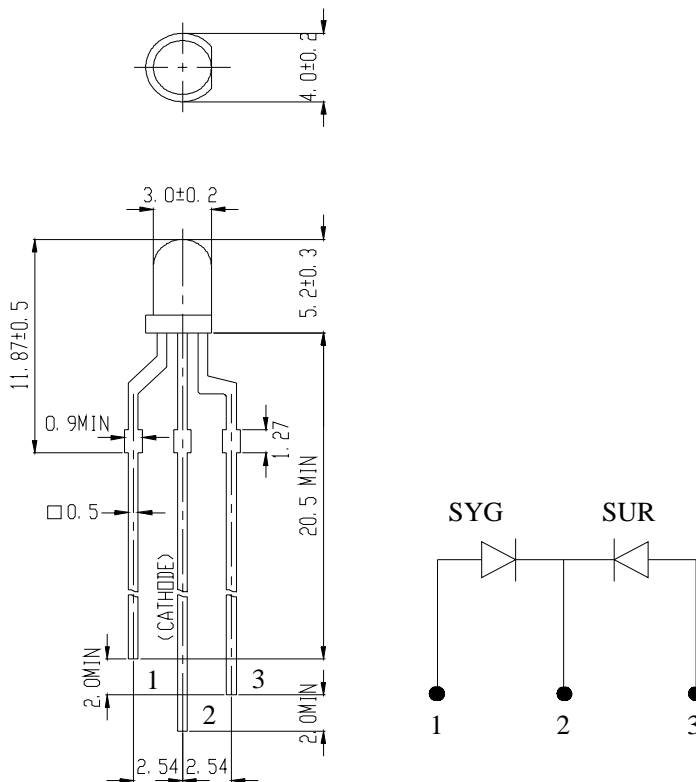

- Notes: 1. All dimensions are in millimetres  
2. An epoxy meniscus may extend about 1.5mm(0.059") down to the lead.  
3. Tolerances unless Dimension  $\pm 0.25$ mm.

■ Absolute Maximum Ratings at  $T_a = 25^\circ\text{C}$

Parameter	Symbol	Rating		Unit
		SUR/S530	SYG/S530	
Forward Current	I <sub>F</sub>	25	25	mA
Operating Temperature	T <sub>opr</sub>	-40 to +85		°C
Storage Temperature	T <sub>stg</sub>	-40 to +100		°C
Soldering Temperature	T <sub>sol</sub>	260 ± 5		°C
Electrostatic Discharge	ESD	2000	2000	V
Power Dissipation	P <sub>d</sub>	60	60	mW
Reverse Voltage	V <sub>R</sub>	5		V

Note: \*1: Soldering time  $\leq 5$  seconds.



Technical Data Sheet  
3.0mm Multi-Color Round Type LED Lamps

209SURSYGW/S530-A3

Electro-Optical Characteristics (Ta=25°C)

Parameter	Symbol		Condition	Min.	Typ.	Max.	Unit
Forward Voltage	SUR/S530	V <sub>F</sub>	I <sub>F</sub> = 20 mA	/	2.0	2.4	V
	SYG/S530			/	2.0	2.4	
Reverse Current	SUR/S530	I <sub>R</sub>	V <sub>R</sub> = 5 V	/	/	10	μ A
	SYG/S530			/	/	10	
Luminous Intensity	SUR/S530	I <sub>v</sub>	I <sub>F</sub> = 20 mA	40	80	/	mcd
	SYG/S530			20	40	/	
Viewing Angle		2θ 1/2	I <sub>F</sub> = 20 mA	/	80	/	deg
Peak Wavelength	SUR/S530	λ <sub>p</sub>	I <sub>F</sub> = 20 mA	/	632	/	nm
	SYG/S530			/	575	/	
Dominant Wavelength	SUR/S530	λ <sub>d</sub>	I <sub>F</sub> = 20 mA	/	624	/	nm
	SYG/S530			/	573	/	
Spectrum Radiation Bandwidth	SUR/S530	Δλ	I <sub>F</sub> = 20 mA	/	20	/	nm
	SYG/S530			/	20	/	



# Technical Data Sheet

## 3.0mm Multi-Color Round Type LED Lamps

209SURSYGW/S530-A3

### Typical Electro-Optical Characteristic Curves:

(SUR)

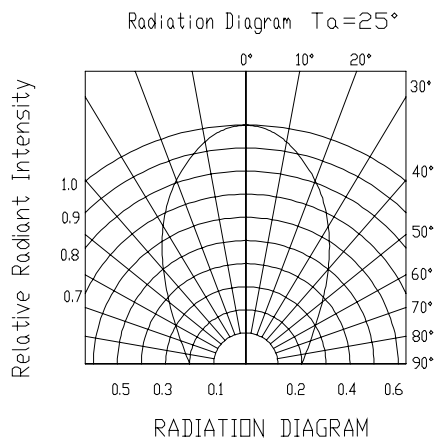
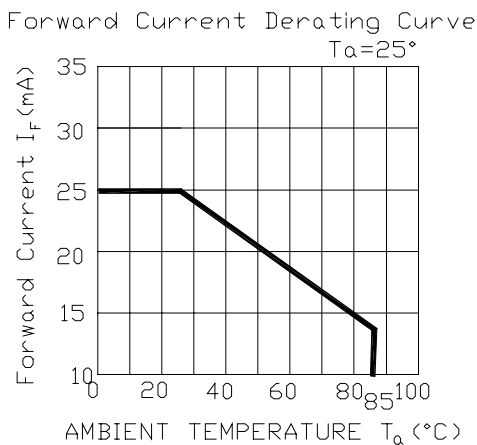
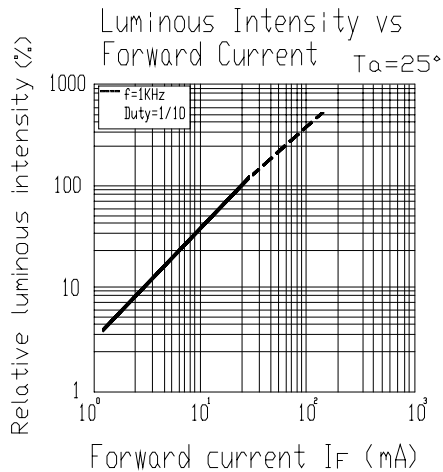
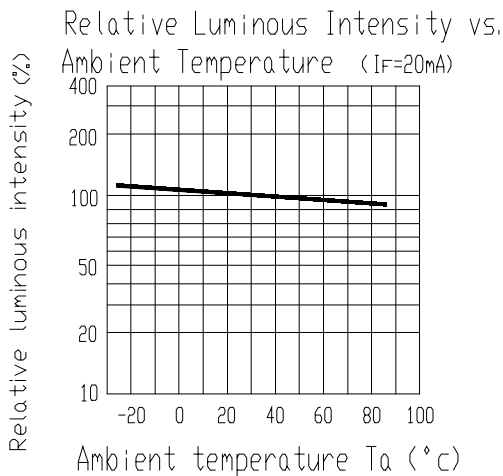
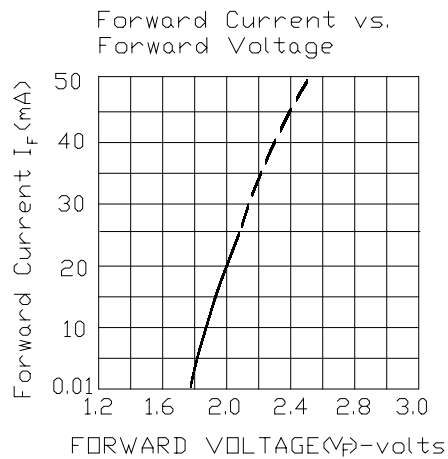
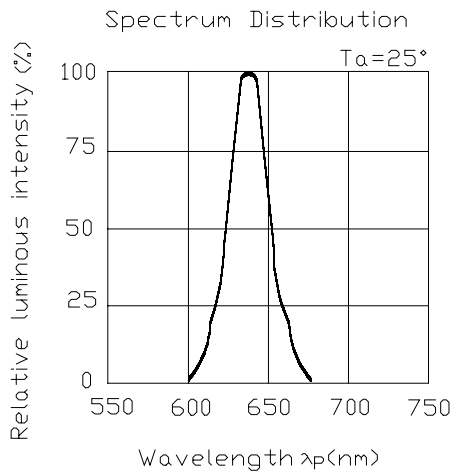



# Technical Data Sheet

## 3.0mm Multi-Color Round Type LED Lamps

209SURSYGW/S530-A3

### Typical Electro-Optical Characteristic Curves:

(SYG)

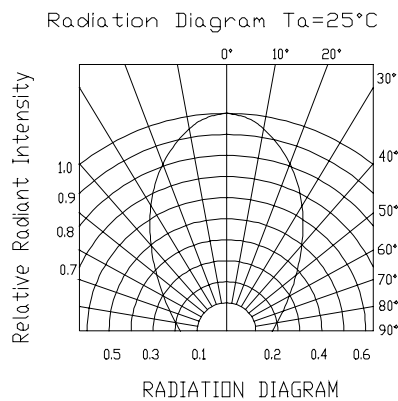
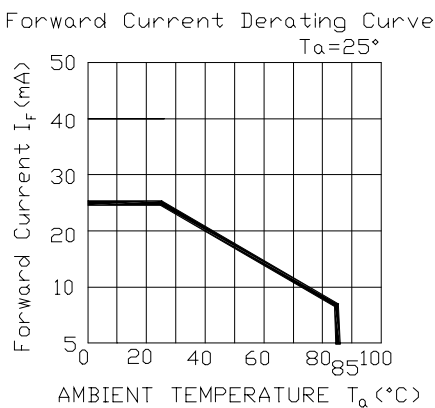
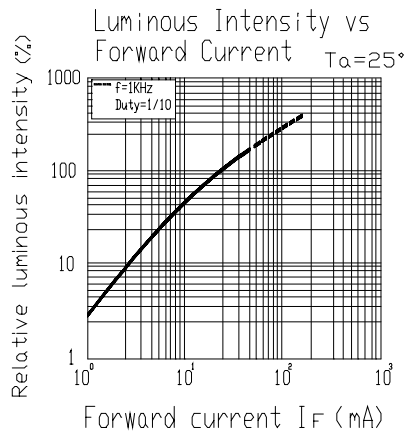
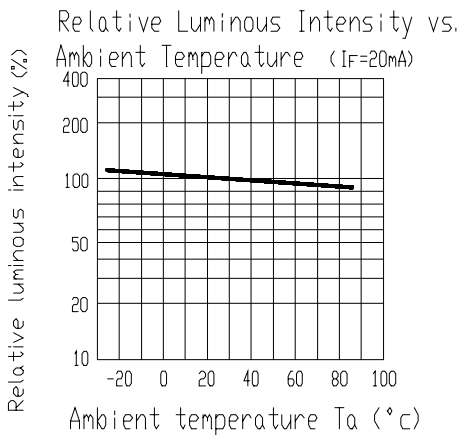
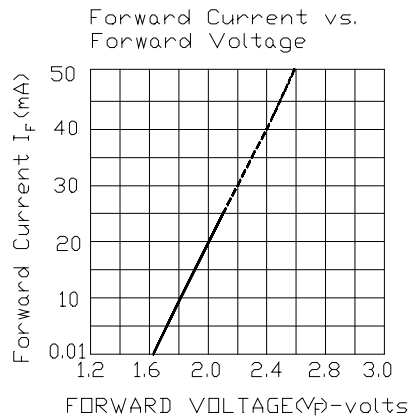
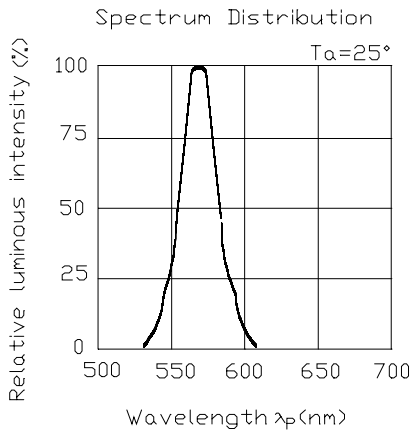



# Technical Data Sheet

## 3.0mm Multi-Color Round Type LED Lamps

209SURSYGW/S530-A3

### ■ Reliability test items and conditions:

The reliability of products shall be satisfied with items listed below.

Confidence level : 97%

LTPD : 3%

NO	Item	Test Conditions	Test Hours/Cycle	Sample Size	Failure Judgment Criteria	Ac/Re
1	Solder Heat	TEMP : 260°C ± 5 °C	10 SEC	76 PCS	Iv ≤ Ivt*0.5 or Vf ≥ U or Vf ≤ L	0/1
2	Temperature Cycle	H : +100°C 15min ∫ 5 min L : -40°C 15min	300 CYCLES	76 PCS		0/1
3	Thermal Shock	H : +100°C 5min ∫ 10 sec L : -10°C 5min	300 CYCLES	76 PCS		0/1
4	High Temperature Storage	TEMP : 100°C	1000 HRS	76 PCS		0/1
5	Low Temperature Storage	TEMP : -40°C	1000 HRS	76 PCS		0/1
6	DC Operating Life	TEMP : 25°C IF = 20mA	1000 HRS	76 PCS		0/1
7	High Temperature / High Humidity	85°C / 85% RH	1000 HRS	76 PCS		0/1

Note : Ivt : To test Iv value of the chip before the reliability test  
Iv : The test value of the chip that has completed the reliability test  
U : Upper Specification Limit  
L : Lower Specification Limit



# Technical Data Sheet

## 3.0mm Multi-Color Round Type LED Lamps

209SURSYGW/S530-A3

### Packing Quantity Specification

1.500PCS/1Bag , 4Bags/1Box

2.10Boxes/1Carton

### Label Form Specification

EVERLIGHT

CPN:

P/N:



209SURSYGW/S530-A3

QTY:



CAT:

HUE:

REF:

LOT NO: EL



CPN: Customer's Production Number

P/N : Production Number

QTY: Packing Quantity

CAT: Ranks

HUE: Dominant Wavelength

REF: Reference

LOT No: Lot Number

### Notes

1. Above specification may be changed without notice. EVERLIGHT will reserve authority on material change for above specification.
2. When using this product, please observe the absolute maximum ratings and the instructions for using outlined in these specification sheets. EVERLIGHT assumes no responsibility for any damage resulting from use of the product which does not comply with the absolute maximum ratings and the instructions included in these specification sheets.
3. These specification sheets include materials protected under copyright of EVERLIGHT corporation. Please don't reproduce or cause anyone to reproduce them without EVERLIGHT's consent.