



Standard Test Method for Tear Strength of Conventional Vulcanized Rubber and Thermoplastic Elastomers¹

This standard is issued under the fixed designation D 624; the number immediately following the designation indicates the year of original adoption or, in the case of revision, the year of last revision. A number in parentheses indicates the year of last reappraisal. A superscript epsilon (ϵ) indicates an editorial change since the last revision or reappraisal.

This standard has been approved for use by agencies of the Department of Defense.

^{ε1} NOTE—The table in Fig. 1 on DIE C was corrected editorially in March 2001.

1. Scope

1.1 This test method describes procedures for measuring a property of conventional vulcanized rubber and thermoplastic elastomers called tear strength.

1.2 The values stated in SI units are to be regarded as the standard. The values given in parentheses are for information only.

1.3 *This standard does not purport to address all of the safety concerns, if any, associated with its use. It is the responsibility of the user of this standard to establish appropriate safety and health practices and determine the applicability of regulatory limitations prior to use.*

2. Referenced Documents

2.1 ASTM Standards:

- D 412 Test Methods for Vulcanized Rubber and Thermoplastic Rubbers and Thermoplastic Elastomers – Tension²
- D 1349 Practice for Rubber— Standard Temperatures for Testing²
- D 3182 Practice for Rubber— Materials, Equipment, and Procedures for Mixing Standard Compounds and Preparing Standard Vulcanized Sheets²
- D 3183 Practice for Rubber— Preparation of Pieces for Test Purposes from Products²
- D 3767 Practice for Rubber— Measurement of Dimensions²
- D 4483 Practice for Determining Precision for Test Method Standards in the Rubber and Carbon Black Industries²

2.2 ISO Standard:

- ISO/34 Rubber, Vulcanized – Determination of Tear Strength (Trouser, Angle, and Crescent Tear Pieces)³

3. Terminology

3.1 The tear of rubber is a mechanical rupture process initiated and propagated at a site of high stress concentration

caused a cut, defect, or localized deformation. The following definitions define different techniques for measuring the resistance to tear, i.e. the tear strength, required for use with this standard.

3.2 Definitions of Terms Specific to this Standard:

3.2.1 *Type A tear strength*—the maximum force required to cause a nick or cut in a Type A (nicked crescent) test piece to grow by tearing the rubber, divided by the thickness of the test piece.

3.2.2 *Type B tear strength*—the maximum force required to cause a nick or cut in a Type B (nicked tab end) test piece to grow by tearing the rubber, divided by the thickness of the test piece.

3.2.3 *Type C tear strength*—the maximum force required to cause a rupture of a Type C (right angle) test piece, divided by the thickness of the test piece.

3.2.4 *Type T or trouser tear strength*—the mean or median force, calculated in accordance with procedures in this method, required to propagate a tear in a Type T (trouser) test piece, divided by the thickness of the test piece.

3.2.5 *Type CP or constrained path tear strength*—the mean or median force, calculated in accordance with procedures in this method, required to propagate a tear in a type CP (constrained path) test piece, divided by the thickness of the torn section.

3.2.6 *complete trace*—the section of a graphical plot of force versus jaw separation distance between the point at which the first peak occurs and the point at which the test is terminated.

3.2.7 *peak*—a point at which the slope of a trace changes from positive to negative.

3.2.8 *range*—the difference between the greatest and the smallest observed test values.

3.2.9 *valley*—a point at which the slope of a trace changes from negative to positive.

4. Summary of Test Method

4.1 A tearing strain (and stress) is applied to a test specimen by means of a tensile testing machine operated without interruption at a constant rate of crosshead traverse until the specimen is completely torn.

¹ This test method is under the jurisdiction of ASTM Committee D11 on Rubber and is the direct responsibility of Subcommittee D11.10 on Physical Testing.

Current edition approved July 10, 2000. Published September 2000. Originally published as D 624 – 41T. Last previous edition D 624 – 98.

² *Annual Book of ASTM Standards*, Vol 09.01.

³ Available from American National Standards Institute, 11 West 42nd St., 13th Floor, New York, NY 10036.

4.2 This test method measures the force per unit thickness required to rupture, initiate, or propagate a tear through a sheet of rubber in the form of one of several test piece geometries:

4.2.1 Type A, a razor-nicked test piece with a crescent shape, as shown in Fig. 1, Die A. The force in this test piece acts in a direction substantially along the major axis (length) and perpendicular to the “nick”, or razor cut. Type A is used to measure tear propagation and is normally cut from smaller test specimens that can not accommodate other test types.

4.2.2 Type B, a razor-nicked test piece with a crescent shape and with tab ends, as shown in Fig. 1, Die B. The force in this test piece acts in a direction substantially along the major axis (length) and perpendicular to the “nick”, or razor cut. Type B also measures tear propagation and is preferred over Type A when the test sample allows.

4.2.3 Type C, an un-nicked test piece with a 90° angle on one side and with tab ends, as shown in Fig. 1, Die C. The force acts on the test piece in a direction substantially parallel to the

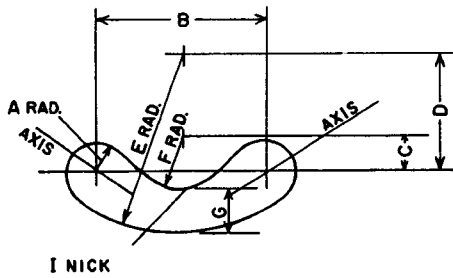

DIE A

Dimension	Millimetres		Inches	
	Value	Tolerance	Value	Tolerance
A	7.6	±0.05	0.3	±0.002
B	42	±0.50	1.65	±0.02
C	8.6	±0.05	0.34	±0.002
D	29	±0.05	1.14	±0.002
E	43.2	±0.05	1.7	±0.002
F	12.7	±0.05	0.5	±0.002
G	10.2	±0.05	0.4	±0.002
Nick [^]	0.50	±0.05	0.02	±0.002

[^] Nick to be cut in specimen with a razor.

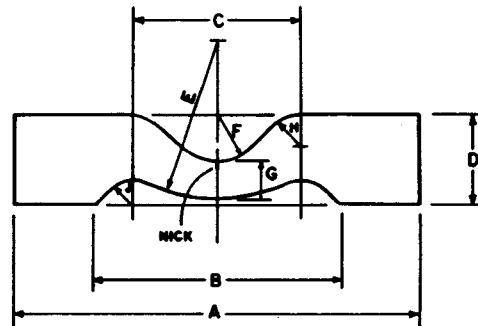

DIE B (ISO/ 34 CONFIGURATION)

Dimension	Millimetres		Inches	
	Value	Tolerance	Value	Tolerance
A	110	±0.50	4.3	±0.02
B	68	±0.50	2.7	±0.02
C	45	±0.05	1.8	±0.002
D	25	±0.05	1	±0.002
E	43	±0.05	1.7	±0.002
F	12.5	±0.05	0.5	±0.002
G	10.2	±0.05	0.4	±0.002
H	9	±0.05	0.375	±0.002
J	7.5	±0.05	0.3	±0.002
Nick [^]	0.5	±0.05	0.02	±0.002

[^] Nick to be cut in specimen with a razor.

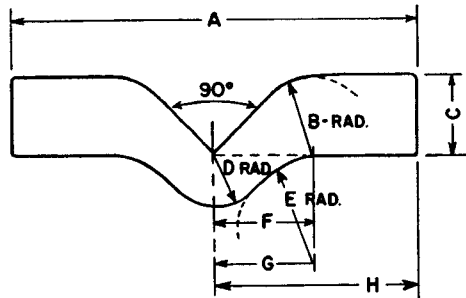

DIE C

Dimension	Millimetres		Inches	
	Value	Tolerance	Value	Tolerance
A	102	±0.50	4.0	±0.02
B	19	±0.05	0.75	±0.002
C	19	±0.05	0.75	±0.002
D	12.7	±0.05	0.5	±0.002
E	25	±0.05	1.0	±0.002
F	27	±0.05	1.061	±0.002
G	28	±0.05	1.118	±0.002
H	51	±0.25	2.0	±0.01

FIG. 1 Type A, B and C Tear Test Specimen Cutting Dies

tab ends of the specimen (45° to the 90° center angle) in the direction of grip separation. Type C measures rupture, or tear initiation strength at the stress concentration located at the 90° apex. If tear initiation does not occur at the apex, the results are more indicative of tensile strength than tear strength.

4.2.4 Type T, a trouser tear test piece, as shown in Fig. 2. Type T measures tear propagation in a direction parallel to the length of both legs.

4.2.5 Type CP, a test piece described in Fig. 3, which is a modified trouser tear test piece with a constrained path for the tear. Type CP also measures tear propagation in a direction parallel to the length of both legs, but the constrained path prevents the tear from propagating away from this path, and the thicker legs eliminate the influence of leg extension which may occur with Type T test pieces. See (1) for more information on CP tear testing.

4.3 No Correlation of results from one test type to another should be expected, as each test type measures tear strength for a different tear specimen geometry.

5. Significance and Use

5.1 Vulcanized rubber and thermoplastic elastomers (TPE) often fail in service due to the generation and propagation of a special type of rupture called a tear. This test method measures the resistance to tearing action.

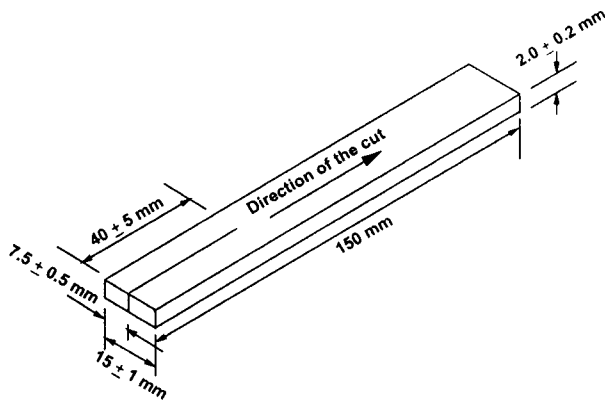

Positioning of trouser tear test piece in testing machine

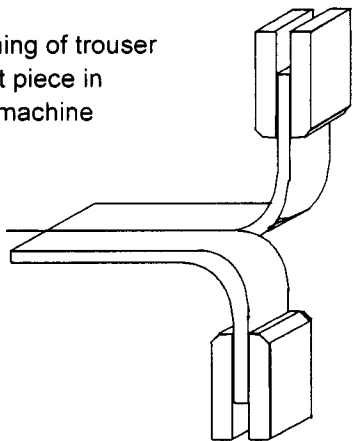

FIG. 2 Trouser Tear Test Specimen

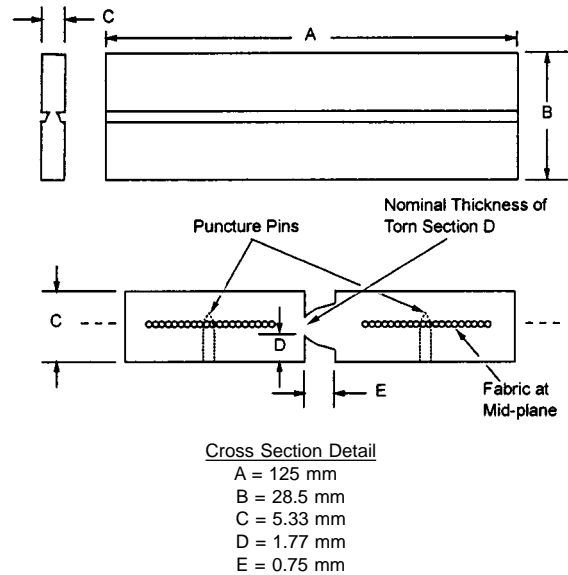

FIG. 3 Schematic diagram of "Constrained Path" tear test piece (1)

5.2 Tear strength may be influenced to a large degree by stress-induced anisotropy (mechanical fibering), stress distribution, strain rate, and test piece size. The results obtained in a tear strength test can only be regarded as a measure under the conditions of that particular test and may not have any direct relation to service performance. The significance of tear testing must be determined on an individual application or product performance basis.

6. Apparatus

6.1 *Testing Machine*—The testing machine shall conform to the requirements as specified in Test Method D 412. It shall be capable of registering the applied forces within ± 2 % of the total force range or capacity during the test while maintaining the specified rate of jaw separation:

6.1.1 For Type A, B or C test pieces, the rate of jaw separation shall be 500 ± 50 mm/min. (20 ± 2.0 in./min.).

6.1.2 For Type T and Type CP test pieces, the rate of jaw separation shall be 50 ± 5 mm/min. (2 ± 0.2 in./min.).

6.1.2.1 A low inertia machine having a continuous recording of force is essential when using the Type T or Type CP trouser tests.

NOTE 1—Inertia (pendulum) type dynamometers may give results which differ from one another because of frictional and inertial effects. A low inertia (electronic or optical transducer) dynamometer gives results which are free from these effects and is preferred.

6.1.3 Calibration of the testing machine shall be routinely verified according to the manufacturer's recommendations. Verification of calibration shall be evidenced by a written record which shows the date of verification and the testing machine's accuracy at that time.

6.2 The test may be conducted at elevated or lower temperatures listed in D 1349 using equipment described in Test Method D 412.

6.3 *Grips*—The testing machine shall be equipped with grips that tighten automatically and exert a uniform pressure

across the gripping surfaces. Grips shall provide adequate pressure as tension increases to prevent specimen slippage. Constant pressure pneumatic grips are satisfactory for most specimens. Test pieces shall be inserted in the grips symmetrically positioned and in axial alignment with the direction of pull. The depth of insertion of the test piece in the grips must be consistent and sufficient to prevent slipping. Type T and Type CP specimens shall be inserted in the grips as shown in Fig. 2.

6.4 Test Piece Cutting Dies—Test pieces for tear strength shall be cut from a test specimen using cutting dies conforming to one of the shapes described in Figs. 1 and 2, or molded according to Fig. 3 for Type CP tests.

6.4.1 The inside faces of the cutting dies shall be perpendicular to the plane formed by the cutting edges and polished for a distance of at least 5 mm (0.2 in.) from the cutting edge. The die shall at all times be sharp and free from nicks.

6.4.2 It is important that the apex of the 90° angle in Die C be sharpened to provide a sharp corner. If a segmented Die C is used, the segment incorporating the apex shall extend a minimum of 25 mm from the apex in both directions.

6.4.3 Test piece cutting dies shall be routinely examined and verified for accuracy. One method may be by preparing a test piece and measuring it for conformance to the dimensions listed in Figs. 1 and 2. Another method may be by testing of a control compound and comparing the test results with those obtained with a compound of the same formulation using dies known to be accurate. Verification shall be documented by a dated written record.

6.5 Nicking devices are used to make an initial cut in test pieces for Type A or B tests.

6.5.1 The nicking device shall secure the test piece in a manner that prevents movement, so that the cutting mechanism introduces a razor blade on a plane perpendicular to the major axis of the test piece. The blade shall be positioned to produce a precisely controlled and cleanly separated cut in the specimen. Alternatively, a nicking die may also provide acceptable results so long as the die is routinely examined and verified for accuracy as specified in 6.4.3.

7. Test Piece Preparation

7.1 Cut test pieces shall be obtained from molded test specimen sheets. Compression molded test specimen sheets shall use molds conforming to Practice D 3182. Molded test specimen sheets may also be prepared by injection molding into plaques. For test pieces cut from products, Practice D 3183 shall be followed.

7.1.1 Molded test specimen sheets shall be 2.3 ± 1.0 mm (0.09 ± 0.04 in.) thick with the milling grain or flow direction clearly marked.

7.1.2 Injection molded test specimen sheets may not have the same degree of anisotropy as compression molded sheets, and this may affect the tear test results. In injection molded sheets, the grain direction is parallel to the flow direction.

7.1.3 Anisotropy may also affect results for test pieces cut from products. A record of the orientation of cut test pieces shall also be made in these cases.

7.2 Molded test pieces are molded in shapes defined by the specifications in Fig. 1, Fig. 2 or Fig. 3. Molded test pieces may

produce different results from cut test pieces.

7.3 The usual practice is to test with the grain running the length of the test piece. For Type A, B and C test pieces, the tear would thus be recorded as across the grain. It is to be assumed, unless otherwise specified, that all Type A, B or C test pieces are prepared in this manner. Type T and CP test pieces are also prepared with the grain running parallel to the length. This means that for Type T and CP tests the tear will be parallel to the grain. Where grain effects are significant and are to be evaluated, an additional set of test pieces shall be prepared with the grain running across the length. Results so obtained shall be recorded as with the grain for Type A, B or C tests and across the grain for Type T and CP tests.

7.4 Using the cutting die for the desired test type, cut the test pieces from the sheet with a single impact stroke (by hand or machine) to ensure smooth cut surfaces.

7.5 For Type A and B test pieces, nick the test piece using the nicking device described in 6.5.1. Wet the blade with water or soap solution prior to nicking the test piece. Nick the test piece to a depth of 0.50 ± 0.05 mm (0.020 ± 0.002 in.) with a single stroke of the blade. If a nicking die is used, the nick is formed when the test piece is cut from the sheet.

7.5.1 To assure a proper cut with the nicking device, one or two preliminary nicks shall be made on extra test pieces and the depth of the cut checked using a microscope with a minimum of 10× magnification.

7.6 For Type T and CP test pieces, an initial cut should be made with a razor blade or sharp knife. The last 1 mm (approximately) of the cut shall be made with a single stroke.

7.6.1 Type T test pieces shall have an initial cut of 40 ± 5 mm as shown in Fig. 2.

7.6.2 Type CP test pieces shall have an initial cut of 60 ± 5 mm made down the groove between the two legs.

7.7 Three test pieces per sample shall be tested for tear strength, and the median value of the test pieces reported as a test result. If an individual test piece tear strength value deviates by more than 20% from the median of all three test pieces, two additional test pieces shall be tested and the median of all five values reported.

7.7.1 Tear testing is inherently a highly variable measurement since it has many characteristics similar to fatigue testing and is known to give widely dispersed test results, frequently with a non-normal distribution. For referee tear testing, a minimum of five test pieces is recommended.

7.8 Measure the thickness of each test piece.

7.8.1 For Type A, B, and C test pieces, measure the thickness at three places across the width, near the center, using a micrometer conforming to Practice D 3767. One of the measurements should be at the slit or apex. Record the median value for calculation of test results.

7.8.2 For Type T test pieces, measure the thickness at three places across the length and record the median value.

7.8.3 For Type CP test pieces, the thickness of the tear path may be measured one of two ways: (1) the total thickness of the test piece along the groove is measured at three places, averaged, and 3.60 mm is subtracted to account for the mold insert sections that form the groove; or (2) the torn surface is examined with a small binocular magnifier with a graduated

reticle and the thickness measured and averaged. The second method is more accurate, but the two methods have been found to agree to within about 5 %. For routine work the first method has been found to be satisfactory. Based on the mold dimensions, the thickness is approximately between 1.70 and 1.80 mm.

8. Test Piece Conditioning

8.1 Cut surfaces of vulcanized rubber undergo a change over a period of time that may affect the initiation of tearing. Therefore, it is important that the conditioning intervals after using cutting dies, nicking devices, razor blades or knives be followed. Deviation from these intervals may affect the test results.

8.2 Test pieces shall be protected from exposure to light during the interval from vulcanization to testing.

8.3 The minimum time between vulcanization and testing shall be 16 h.

8.4 Test pieces shall be conditioned at a standard laboratory temperature of $23 \pm 2^\circ\text{C}$ as defined in Practice D 1349 for a minimum of 3 h before nicking or cutting. If the material is affected by moisture, the relative humidity shall be maintained at $50 \pm 5\%$ and the specimen shall be conditioned for 24 h prior to testing.

8.5 Test pieces may be nicked or cut and tested immediately after conditioning but the maximum time between nicking or cutting and testing shall be 24 h.

8.6 If test piece preparation involves buffing, the interval between buffing and testing shall not exceed 72 h. Nicking or cutting shall be performed after any aging treatment.

8.7 If the test is to be carried out at a temperature other than a standard laboratory (room) temperature, the test pieces shall be conditioned at the test temperature for a minimum time sufficient to reach temperature equilibrium prior to testing. This period should be kept as short as possible to avoid aging the test pieces.

9. Test Temperature

9.1 Unless otherwise specified, the standard test temperature shall be $23 \pm 2^\circ\text{C}$ ($73.4 \pm 3.6^\circ\text{F}$). When testing at some other temperature is required, the temperature specified shall be one of those listed in Practice D 1349, and the report shall include a statement of the test temperature and the length of time the test piece was conditioned.

10. Test Procedure

10.1 Prepare the test pieces and condition them as described in Sections 7 and 8.

10.2 Place the test piece in the grips of the testing machine using care to adjust the test piece so that it will be strained uniformly along its length, and that sufficient material is clamped in the grips to minimize slippage.

10.3 Start the machine at a steady rate of grip separation.

10.3.1 For Type A, B or C test pieces, the rate of jaw separation shall be 500 ± 50 mm/min. (20 ± 2.0 in./min.).

10.3.2 For Type T and Type CP test pieces, the recommended rate of jaw separation shall be 50 ± 5 mm/min. (2 ± 0.2 in./min.).

10.4 Strain the test piece until it is completely ruptured.

10.5 Record the maximum force for Type A, B or C test pieces. For Type T or CP test pieces, make a strip chart or a continuous recording of the force throughout the tearing process.

11. Calculation

11.1 Calculate the tear strength, T_s , in kilonewtons per meter of thickness, by the formula:

$$T_s = F/d \tag{1}$$

Where:

F = the maximum force, in N, for Types A, B or C. For Type T and CP tests, F is the peak, valley, mean or median force obtained from the recording or autographic trace, in N (See 11.3), and

d = the median thickness of each test piece, in mm.

11.1.1 When anisotropic effects are evaluated, determine the median and the range of the values for each direction. Express the results to the nearest 0.1 kN/m.

11.1.2 Alternatively, the tear strength may be expressed in lbf/in. To convert from lbf/in to kN/m, multiply by 0.175.

11.2 The recorded plot of stress versus displacement for Type A, B or C test pieces is a sharply increasing force until catastrophic failure occurs, at which point the force sharply decreases. The peak or maximum force value is used to calculate the tear strength.

11.3 For Type T and CP test pieces, the complete trace of force throughout the tearing process forms a saw-toothed curve consisting of peaks and valleys. Two primary types of saw toothed curves, *a* and *b* are illustrated in Fig. 4. Saw toothed curves can be interpreted in several different ways.

11.3.1 Curve *a* in Fig. 4 illustrates a characteristic tear commonly called “knotty tear”. The word “knotty” designates a large magnitude transient increase in tearing force followed by a precipitous decrease. With this type of tear, the increase-decrease process repeats in a cyclic fashion. Each increasing force stage eventually produces a rapid tear rupture which relieves concentrated stress and increases torn length. Just as the maximum force reached before tearing is a measure of tear

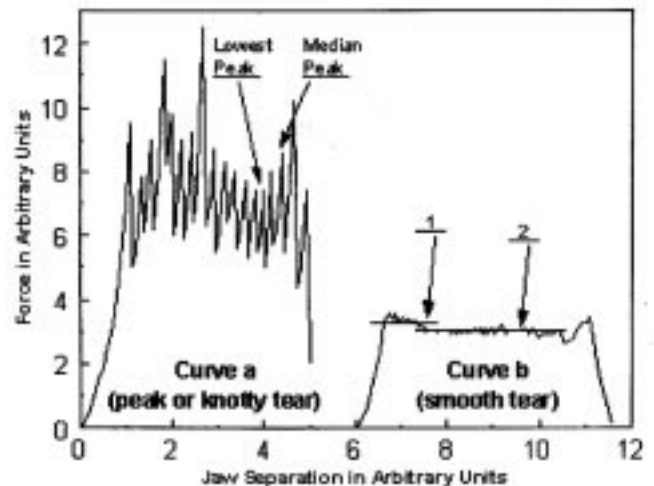

FIG. 4 Smooth Tear and Knotty Tear Curve Types

strength, the level to which the force decreases before tear pauses also indicates important compound tear properties.

11.3.2 Curve *b* in Fig. 4 illustrates a typical “smooth tear” curve with minimal tear force amplitudes between the tear initiation force and the tear pause force.

11.4 *Peak Only Analysis* uses the peak forces generated during the tearing process. The peak force value obtained defines the maximum stress concentration that the compound will bear before catastrophic failure occurs. This method should be used on curves resembling example *a* in Fig. 4.

11.4.1 The sum of the peak force values divided by the number of peaks defines the mean peak force.

11.4.2 In establishing the repetitive pattern of transient tearing that creates the saw-toothed curve, it is not uncommon to have the initial or final peaks, or both, be inconsistent in magnitude with those in the center of the curve. Such peaks can be abnormally low or high depending on the physical properties of the compound and how quickly the transient tear pattern is established or ended. For any complete trace, individual peak force values that deviate from the mean by 20 % or more should be discarded and a new mean calculated to correct for abnormal values.

11.5 *Valley Only Analysis* uses the forces (opposite of peaks) at the valley positions on the saw-toothed curve as a measure of the force to which the stress concentration must be relaxed for tearing to cease. This method should be used on curves resembling example *a* in Fig. 4.

11.5.1 The sum of the forces at each valley are divided by the number of valleys to calculate the mean valley force. As with the peak only analysis, initial and final valley forces may be abnormal. For any complete trace, individual valley force values that deviate from the mean by 20 % or more should be discarded and a new mean calculated to correct for abnormal values.

11.6 *Mean Force Analysis* of type *a* curves in Fig. 4 uses the arithmetic mean of the mean peak force and the mean valley force. This should be considered as an average tear force since it gives equal consideration to peak and valley responses. Note that the mean force does not indicate the difference between peak and valley forces. It is possible for two tear curves to have the same mean force when one has a large difference between peaks and valleys, while the other has a small difference between peaks and valleys.

11.7 *Peak and Valley Analysis* uses a concise report of type *a* curves in Fig. 4 as the mean force value with a plus or minus value determined by the average of the greatest four to six peak force values and the average of the lowest four to six valley force values.

11.8 *Total Work Analysis* measures the total work required to tear the test piece by measuring the area under the force-displacement test curve. The area can be measured electronically by properly equipped instruments or measured manually by use of a planimeter. The mean force can be calculated by dividing the area under the curve by the displacement indicated on the complete trace curve. As with other mean tear force values, the total work analysis method does not account for the magnitude of variation from the mean. The total work analysis method can be used on both types of

curves shown in Fig. 4.

11.9 *Manual Curve Analysis* may also be used as a method of calculating median mean force values.

11.9.1 *Manual Curve Analysis for Type a Curves (Knotty Tear)*—Count the number of peaks. To obtain the median force value, locate, with a horizontal line, the lowest or No. 1 peak force value. Move upward from this line the required number of peaks to arrive at the median peak force value. In Fig. 4, the lowest peak force and the median peak force points are identified.

11.9.2 *Manual Curve Analysis for Type b Curves (Smooth Tear)*—Smooth type tear curves often consist of a series of tear propagation or torn length sequences, each at essentially constant tearing force. In Fig. 4, Curve *b* shows two such sequences (1) and (2), with (2) approximately twice the length of (1). The tear strength for this type of curve should be calculated based on a weighted average force basis. A median force is specified for Type *b* tear curves because it is easier to obtain than an average, and it does not give undue weight to abnormally large or small peak forces.

11.9.3 A general formula for weighted average tear force is:

$$\text{Tear Force (Weighted Average)} = \frac{n_0 (TF_1) + N_2 (TF_2) + \dots N_i (TF_i)}{\Sigma(n_i)} \quad (2)$$

where:

- n_0 = smallest observable segment (chart distance) for a constant tear force segment,
- N_2 = n_2/n_0 = the weighting factor for constant tear force (TF) segment TF_2 , with n_2 as the actual segment distance for TF_2 , and
- $\Sigma(n_i)$ = the sum of all n_0 values, or total torn length, or chart paper distance measured in n_0 units.

12. Report

12.1 Report the following information:

12.1.1 Median test results of three or five test pieces, calculated in accordance with Section 11.

12.1.2 Indicate which Type of test piece was used (A, B, C, T or CP) and whether the test piece was die cut, molded to form, or obtained from a product.

12.1.3 For Type T, and CP test pieces the tear curve analysis method shall also be specified.

12.1.4 Test piece thickness.

12.1.5 The depth of the nick for Type A or B test pieces.

12.1.6 Grain direction if other than the conventional orientation (see Section 7.3). Indicate as with the grain or across the grain, or unknown if the conventional orientation is not followed.

12.1.7 Maximum force, *F* for Type A, B or C test pieces, or the mean or median force for Type T and CP test pieces. For Type T and CP test pieces with tear curves similar to curve *a* in Fig. 4, the mean or median peak and the mean or median valley forces should also be reported.

12.1.8 Date of test and date of vulcanization of the test sample, if known.

12.1.9 Test temperature, when the test is conducted at conditions other than standard room temperature.

12.1.10 Relative humidity when it is known that the material is sensitive to humidity.

12.1.11 Type of testing machine and grips employed.

12.1.12 Any other details that are pertinent to the history of the test piece.

13. Precision and Bias ⁴

13.1 This precision and bias section has been prepared in accordance with Practice D 4483. Refer to this practice for terminology and other statistical calculation details.

13.2 A Type 1 (interlaboratory) precision was evaluated in 1981 and another in 1988. Test repeatability and reproducibility are short term; a period of a few days separates replicate test results. A test result is the median value, as specified by this method, obtained on three determinations or measurements.

13.3 In the 1981 test program, one material (one rubber compound) was tested in four laboratories on two separate days. In the 1983 test program, two materials (rubbers) were tested in five laboratories on two separate days. For both programs tests were conducted for dies B and C only.

13.4 The results of the precision calculations for repeatability and reproducibility are given in Tables 1 and 2.

13.5 The precision of this test method may be expressed in the format of the following statements which use an appropriate value of *r*, *R*, (*r*) or (*R*), that is, that value to be used in decisions about test results (obtained with the test method). The appropriate value is that value of *r* or *R* associated with a mean level in the precision tables closest to the mean level under consideration at any given time, for any given material in routine testing operations.

13.6 *Repeatability*—The repeatability, *r*, of this test method has been established as the appropriate value tabulated in the

TABLE 1 Type 1 Precision for Dies B and C (1981)^A

Die	Average Value (kN/m)	Within Laboratories			Between Laboratories		
		<i>S_r</i>	<i>r</i>	(<i>r</i>)	<i>S_R</i>	<i>R</i>	(<i>R</i>)
B	81.6	5.11	14.5	17.7	16.8	47.6	58.3
C	44.5	3.84	10.9	24.4	4.69	13.3	29.8

^A*S_r* = repeatability standard deviation.

r = repeatability = 2.83 × *S_r*.

(*r*) = relative repeatability, expressed as a percentage of the average value.

S_R = reproducibility standard deviation.

R = reproducibility = 2.83 × *S_R*.

(*R*) = relative repeatability, expressed as a percentage of the average value.

precision tables. Two single test results, obtained under normal test procedures, that differ by more than this tabulated *r* (for any given level) must be considered as derived from different or non-identical sample populations.

13.7 *Reproducibility*—The reproducibility, *R*, of this test method has been established as the appropriate value tabulated in the precision tables. Two single test results obtained in two different laboratories, under normal test method procedures, that differ by more than the tabulated *R* (for any given level) must be considered to have come from different or non-identical sample populations.

13.8 Repeatability and reproducibility expressed as a percentage of the mean level, (*r*) and (*R*), have equivalent application statements as above for *r* and *R*. For the (*r*) and (*R*) statements, the difference in the two single test results is expressed as a percentage of the arithmetic mean of the two test results.

13.9 *Bias*—In test method terminology, bias is the difference between an average test value and the reference (or true) test property value. Reference values do not exist for this test method since the value (of the test property) is exclusively defined by the test method. Bias, therefore, cannot be determined.

14. Keywords

14.1 tear resistance; tear strength; tear propagation; nicked tear specimen; trouser tear; constrained path tear

⁴ The full details and test results of the interlaboratory test program used for this precision section are contained in a Research Report RR:D11-1027 obtainable from ASTM headquarters.

TABLE 2 Type 1 Precision for Dies B and C (1983)^A

Die	Material	Average Value	Within Laboratories			Between Laboratories		
		(kN/m)	<i>S_r</i>	<i>r</i>	(<i>r</i>)	<i>S_R</i>	<i>R</i>	(<i>R</i>)
B	(1) H14327	47.4	2.29	6.47	13.7	14.4	40.7	85.8
B	(2) R19526	85.1	5.50	15.6	18.3	25.0	70.8	83.2
C	(3) H14327	40.0	1.14	3.23	8.1	9.35	26.4	66.1
C	(4) R19526	49.7	2.83	8.02	16.1	8.58	24.3	48.8

^A*S_r* = repeatability standard deviation.

r = repeatability = 2.83 × *S_r*.

(*r*) = relative repeatability, expressed as a percentage of the average value.

S_R = reproducibility standard deviation.

R = reproducibility = 2.83 × *S_R*.

(*R*) = relative repeatability, expressed as a percentage of the average value.

APPENDIX

(Nonmandatory Information)

X1. SIGNIFICANCE OF DIFFERENT TEAR TEST METHODS

X1.1 Background

X1.1.1 To characterize rubbers adequately, knowledge of their rupture properties is essential. Tear strength is important in the performance of many rubber products. This appendix gives some background discussion based on the work cited in (1) and (2) at the end of the standard.

X1.1.2 One reason for the lack of discrimination in many tear tests is a direct influence of compound modulus on measured tear strength. Fig. X1.1 is a plot of D 624 Die C tear strength as a function of modulus (300 %) for data taken from the literature. This shows tear strength to be strongly correlated with modulus (correlation coefficient of 0.90). Thus both modulus and tear strength are being measured in unknown proportions. Theoretical calculations show that the tear rupture force of Die C specimen measurements is approximately equal to the square root of the tangent modulus-tear strength product.

X1.1.3 It should not be inferred that modulus will have no effect on tear strength; however, the influence of modulus should be allowed to operate in the immediate tearing zone and not in regions of the test specimen remote from the locus of tear. In short, a tear test specimen should not be an ill-shaped modulus (tensile) test specimen.

X1.1.4 Rivlin, Thomas, et al. (2) developed tear tests based on theoretical analysis of crack growth behavior. For flat sheet test specimens they defined a tearing energy or strength T , that is independent of the geometry of the test specimen provided the stored energy density of the specimen could be measured. Three types of test specimens were used: the strip or tensile specimen, the pure shear specimen and the trouser tear specimen. The relation for the tearing energy with the trouser specimen is:

$$T = 2\lambda F/t - wE \tag{X1.1}$$

where:

T = tear strength in force/unit thickness (per unit length torn),

λ = extension ratio in legs of piece,

F = force applied to ends of piece,

w = total width of specimen,

t = thickness, and

E = strain energy density in legs of piece.

For certain vulcanizates, if w is chosen large enough, the elongation of the legs is minimal ($\lambda \approx 1$) and E is essentially zero. Then:

$$T = 2F/t \tag{X1.2}$$

X1.1.5 Many published reports imply that Eq X1.2 is satisfactory to use for routine tear measurements. However, two serious deficiencies are evident: For many compounds there is appreciable leg extension ($\lambda \neq 1$) even if w is chosen to be quite wide; and secondly knotty tear is frequently encountered and the tear deviates laterally and tears through one leg of the test specimen. Development of Eq X1.1 and X1.2 is based on tear propagation down the central axis of the test piece.

X1.1.6 Leg extension can be allowed for if strain energy density E is known, but a separate stress-strain curve is required. When one leg of the test specimen is torn through, further testing is precluded with that specimen. These deficiencies very often preclude any quick and meaningful routine tear strength measurement with the simple trouser test piece.

X1.1.7 In order to avoid these deficiencies, it is necessary to reinforce the legs to prevent their elongation and to provide a path of least resistance for tear propagation. The "constrained path", or CP tear test specimen, as described in (1), meets this requirement. It is shown in Fig. 3 of D 624 as a molded piece 125 mm long, 28.5 mm wide, with a nominal thickness of 5 mm. A longitudinal groove with the indicated cross-sectional geometry is molded into the piece. The legs are reinforced with fabric placed in the mid-plane of the piece to avoid an appreciable bending moment and to facilitate its reinforcing action during tear testing. The bottom of the mold contains two puncture pins to hold the fabric as the mold is closed and to prevent a lateral fabric shift.

X1.2 Constrained Path Tear Curves

X1.2.1 Two types of tear curves are obtained for various vulcanizates (see Fig. 4 of D 624). For Curve (b), smooth tear, the tearing load fluctuates only slightly and the rate of tear propagation is essentially continuous and roughly equal to one-half that of jaw separation. Curve (a) is typical of knotty tear, consisting of a series of peak loads, each corresponding to

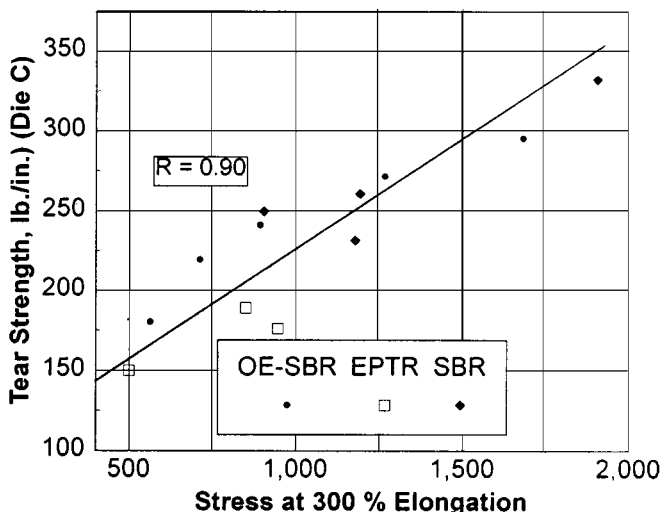

FIG. X1.1 Plot of ASTM Die C Tear Strength as a Function of Stress at 300 % Elongation

a catastrophic tear. This behavior is the result of a strengthening structure or strain energy dissipation process in the immediate tearing zone. The mechanism consists of a build-up of stress in the tearing zone with a concurrent strengthening structure formation. This retards onset of rupture. As stress continues to increase, tear strength is exceeded at some point and a catastrophic rupture occurs. Tear propagation after this rupture is quite rapid and the tear continues to advance until the high stress gradient is removed; the tear rate then drops to zero. The jaws continue to separate, however, and the process repeats several times during a test.

X1.3 Correlation of Constrained Path Tear versus Off Road Tire Performance

X1.3.1 Fig. X1.2 illustrates the degree of correlation between CP tear strength at 100°C and the cutting-chipping rating of a series of compounds in an off-road tire performance test.

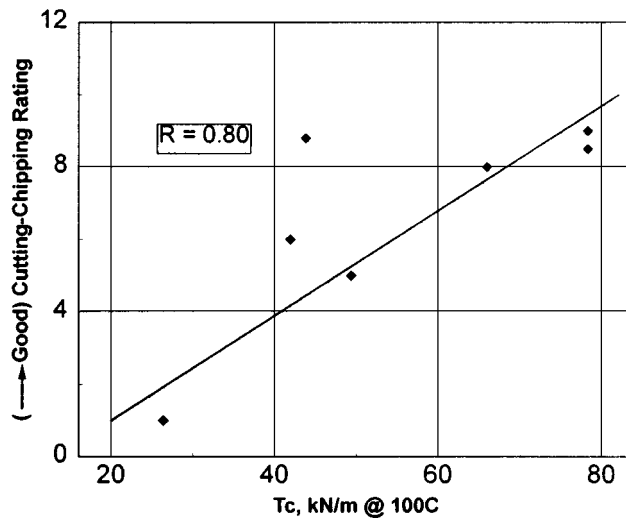

FIG. X1.2 Tear Strength (CP-Test Piece) Tc versus Cutting-Chipping Performance (1)

REFERENCES

- (1) A. G. Veith, "A New Tear Test for Rubber," *Rubber Chemistry and Technology*, 38, 700 (1965).
- (2) R. S. Rivlin, A. G. Thomas, *J. Polymer Science*, 10, 291 (1953).

The American Society for Testing and Materials takes no position respecting the validity of any patent rights asserted in connection with any item mentioned in this standard. Users of this standard are expressly advised that determination of the validity of any such patent rights, and the risk of infringement of such rights, are entirely their own responsibility.

This standard is subject to revision at any time by the responsible technical committee and must be reviewed every five years and if not revised, either reapproved or withdrawn. Your comments are invited either for revision of this standard or for additional standards and should be addressed to ASTM Headquarters. Your comments will receive careful consideration at a meeting of the responsible technical committee, which you may attend. If you feel that your comments have not received a fair hearing you should make your views known to the ASTM Committee on Standards, at the address shown below.

This standard is copyrighted by ASTM, 100 Barr Harbor Drive, PO Box C700, West Conshohocken, PA 19428-2959, United States. Individual reprints (single or multiple copies) of this standard may be obtained by contacting ASTM at the above address or at 610-832-9585 (phone), 610-832-9555 (fax), or service@astm.org (e-mail); or through the ASTM website (www.astm.org).