

铁路专用电源

HR / ER Series 技术指标书



西安泰达华芯科技有限公司

2017年7月



HR / ER Series

144 / 288 Watt 10:1 DC-DC Converters

The ER/HR Series of DC-DC converters represents versatile power supplies ideally suitable for use in transportation and other advanced electronic systems.

The HR Series converters include a very broad input voltage range, very high efficiency, high reliability, low output voltage noise, and excellent dynamic response to load/line changes.

HR converters can be connected to all conventional railway batteries.

ER Series converters are optimized for connection to 110 V railway batteries.

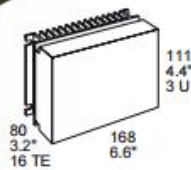
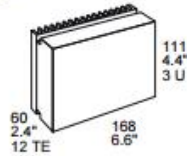

Features

- Extremely wide input voltage range from 12 to 168 VDC in the same converter (HR Series)
- RoHS-compliant for all 6 substances
- Class I equipment
- Compliant with EN 50155, EN 50121, EN 45545
- Input over- and programmable undervoltage lockout
- Shutdown function
- Inrush current limitation
- Interruption time 10 ms
- Adjustable output voltages
- 2 isolated outputs: no load, overload, and short-circuit proof
- Rectangular current limiting characteristic
- Parallel operation with active current sharing
- Very high efficiency up to 94%
- Immunity according to IEC 61000-4-2, -3, -4, -5, -6, -8, -9
- All PCB boards protected by lacquer
- Very high reliability
- 5 year warranty

Safety-approved to the latest edition of IEC/EN 60950-1 and UL/CSA 60950-1



Table of Contents

Description.....	1	Electromagnetic Compatibility (EMC).....	18
Model Selection.....	2	Immunity to Environmental Conditions.....	20
Functional Description.....	5	Mechanical Data.....	21
Electrical Input Data.....	7	Safety and Installation Instructions.....	24
Electrical Output Data.....	10	Description of Options.....	25
Auxiliary Functions.....	15	Accessories.....	26

Description

The converter inputs are protected against surges and transients. An input over- and undervoltage lockout circuitry disables the outputs, when the input voltage is outside of the specified range. To avoid high input currents at operation with high-voltage batteries, the inhibit input allows for adjusting the undervoltage lockout to a suitable level, thus allowing the use of an appropriate external input fuse.

The converters exhibit an inrush current limiter, preventing external circuit breakers and fuses from tripping at switch-on.

The outputs are open- and short-circuit proof.

Full input-to-output, input-to-case, output-to-case, and output to output isolation is provided. The converters are particularly suitable for railway applications. The HR converters can be supplied by all common railway batteries with 24 V, 36 V, 48 V, 72 V, 96 V, 110 V, and 120 V nominal voltage. All PCB boards are coated with a protective lacquer.

The case design allows operation at nominal load up to 71 °C with natural cooling. If forced cooling is provided, the ambient temperature may exceed 71 °C, but the case temperature must remain below 95 °C.

A temperature sensor disables the outputs when the case temperature T_c exceeds the limit. The outputs are automatically re-enabled, when the temperature drops below the limit.

LED indicators display the status of the converter and allow for visual monitoring of the system at any time.

The converters may either be plugged into a 19" rack system according to IEC 60297-3, or be chassis mounted. Two heat sinks of different size and cooling plates for chassis mounting (option B, B1) are available.

Model Selection

Table 1a: Model Selection of HR models

Output 1		Output 2		Power $P_{o\ nom}$ [W]	Input voltage			Efficiency				Model	Options
$V_{o\ nom}$ [V]	$I_{o\ nom}$ [A]	$V_{o\ nom}$ [V]	$I_{o\ nom}$ [A]		$V_{i\ min}$ ³ [V]	$V_{i\ cont}$ [V]	$V_{i\ max}$ ³ [V]	η_{24} ¹		η_{110} ²			
								min [%]	typ [%]	min [%]	typ [%]		
12	20	-	-	240	12	16.8 to 150	168	91	92.5	92	94	HR2320-9RG ⁴	B, B1
12	12	-	-	144	12	16.8 to 150	168	91	92.5	92	94	HRL2320-9RG ⁴	
12	24	-	-	288	12	16.8 to 150	168	91	92.5	92	94	HRP2320-9RG ⁴	
15	16	-	-	240	12	16.8 to 150	168	91	92.5	92	94	HR2540-9RG ⁴	
15	19.2	-	-	288	12	16.8 to 150	168	91	92.5	92	94	HRP2540-9RG ⁴	
48	4	-	-	192	12	16.8 to 150	168	89.5	90.5	92	93	HR2880-9RG ⁴	
48	5	-	-	240	12	16.8 to 150	168	89.5	90.5	92	93	HRP2880-9RG ⁴	
12	10	12	10	240	12	16.8 to 150	168	91	92.5	92	94	HR2320-9RG	B, B1
12	6	12	6	144	12	16.8 to 150	168	91	92.5	92	94	HRL2320-9RG	
12	12	12	12	288	12	16.8 to 150	168	91	92.5	92	94	HRP2320-9RG	
15	8	15	8	240	12	16.8 to 150	168	91	92.5	92	94	HR2540-9RG	
15	9.6	15	9.6	288	12	16.8 to 150	168	90	92.5	92	94	HRP2540-9RG	
48	2	48	2	192	12	16.8 to 150	168	89.5	90.5	92	93	HR2880-9RG	
48	2.5	48	2.5	240	12	16.8 to 150	168	89.5	90.5	92	93	HRP2880-9RG	
24	10	-	-	240	12	16.8 to 150	168	91	92.5	92	94	HR2320-9RG ⁵	B, B1
24	6	-	-	144	12	16.8 to 150	168	91	92.5	92	94	HRL2320-9RG ⁵	
24	12	-	-	288	12	16.8 to 150	168	91	92.5	92	94	HRP2320-9RG ⁵	
30	8	-	-	240	12	16.8 to 150	168	91	92.5	92	94	HR2540-9RG ⁵	
30	9.6	-	-	288	12	16.8 to 150	168	91	92.5	92	94	HRP2540-9RG ⁵	
96	2	-	-	192	12	16.8 to 150	168	89.5	90.5	92	93	HR2880-9RG ⁵	
96	2.5	-	-	240	12	16.8 to 150	168	89.5	90.5	92	93	HRP2880-9RG ⁵	

¹ Efficiency at $T_A = 25\ ^\circ\text{C}$, $V_i = 24\ \text{V}$, $I_{o\ nom} \cdot V_{o\ nom}$

² Efficiency at $T_A = 25\ ^\circ\text{C}$, $V_i = 110\ \text{V}$, $I_{o\ nom} \cdot V_{o\ nom}$

³ Short time; see table 2 for details

⁴ Both outputs connected in parallel

⁵ Both outputs connected in series

Table 1b: Model Selection of ER models

Output 1		Output 2		Power $P_{o\ nom}$ [W]	Input voltage			Efficiency η_{110} ¹		Model	Options
$V_{o\ nom}$ [V]	$I_{o\ nom}$ [A]	$V_{o\ nom}$ [V]	$I_{o\ nom}$ [A]		$V_{i\ min}$ ² [V]	$V_{i\ cont}$ [V]	$V_{i\ max}$ ² [V]	min [%]	typ [%]		
12	20	-	-	240	66	77 to 150	168	93	94	ER2320-9RG ³	B, B1
12	12	-	-	144	66	77 to 150	168	91	94	ERL2320-9RG ³	
12	24	-	-	288	66	77 to 150	168			ERP2320-9RG ³	
15	16	-	-	240	66	77 to 150	168			ER2540-9RG ³	
15	19.2	-	-	288	66	77 to 150	168			ERP2540-9RG ³	
48	4	-	-	192	66	77 to 150	168	90.5	92	ER2880-9RG ³	
48	5	-	-	240	66	77 to 150	168			ERP2880-9RG ³	
12	10	12	10	240	66	77 to 150	168	93	94	ER2320-9RG	
12	6	12	6	144	66	77 to 150	168	91	94	ERL2320-9RG	
12	12	12	12	288	66	77 to 150	168			ERP2320-9RG	
15	8	15	8	240	66	77 to 150	168			ER2540-9RG	
15	9.6	15	9.6	288	66	77 to 150	168			ERP2540-9RG	
48	2	48	2	192	66	77 to 150	168	90.5	92	ER2880-9RG	
48	2.5	48	2.5	240	66	77 to 150	168			EHRP2880-9RG	
24	10	-	-	240	66	77 to 150	168	93	94	ER2320-9RG ⁴	B, B1
24	6	-	-	144	66	77 to 150	168	91	94	ERL2320-9RG ⁴	
24	12	-	-	288	66	77 to 150	168			ERP2320-9RG ⁴	
30	8	-	-	240	66	77 to 150	168			ER2540-9RG ⁴	
30	9.6	-	-	288	66	77 to 150	168			ERP2540-9RG ⁴	
96	2	-	-	192	66	77 to 150	168	90.5	92	ER2880-9RG ⁴	
96	2.5	-	-	240	66	77 to 150	168			ERP2880-9RG ⁴	

¹ Efficiency at $T_A = 25\ ^\circ\text{C}$, $V_i = 110\ \text{V}$, $I_{o\ nom}$, $V_{o\ nom}$

² Short time; see table 2 for details

³ Both outputs connected in parallel

⁴ Both outputs connected in series

Part Number Description

	HR	2	5	40-9	R	B1	G
Operating input voltage $V_{i\text{cont}}$ (continuously):							
16.8 – 150 VDC	HR, HRL, HRP						
77 – 150 VDC	ER, ERL, ERP						
Number of outputs	2, 7 ²						
Nominal voltage of main output $V_{o1\text{nom}}$							
12 V			3				
15 V			5				
24 V			6				
36 V			7				
48 V			8				
Other voltages ¹			9				
Nominal voltage of tracking output V_{o2} ³							
12 V				20			
15 V				40			
24 V				60			
36 V				70			
48 V				80			
Other specifications or additional features ¹				21 – 99			
Operational temperature range: T_A :							
$T_A = -40$ to 71 °C, $T_C \leq 95$ °C							-9
Other ¹							-0, -5, -6
Auxiliary functions and options:							
Output voltage control input					R		
Cooling plate standard case						B, B1	
Cooling plate for long case 220 mm ²						B2 ²	
RoHS-compliant for all 6 substances							G ⁴

- ¹ Customer-specific models. No safety-relevant changes compared to the respective basic model, e.g. different mechanical details, special markings, mounted front plates, reduced output voltage, etc.
- ² Converters with 220 mm case (customer-specific models). Add 5000 to the model number, e.g. HR2540-9RB1G → HR7540-9RB1G.
- ³ The nominal voltages of both outputs are always equal.
- ⁴ G is always placed at the end of the part number.

Note: The sequence of options must follow the order above.

Example: HR2540-9RB1G: DC-DC converter, operating input voltage range 16.8 – 150 VDC, 2 isolated outputs, each providing 15 V, 8 A, control input R to adjust the output voltages, cooling plate B1, and RoHS-compliant for all six substances.

Product Marking

Basic type designation, approval marks, CE mark, warnings, pin allocation, patents, MELCHER logo, specific type designation, input voltage range, nominal output voltages and output currents, degree of protection, identification of LEDs, batch no., serial no. and data code including production site, version, and production date.

Functional Description

The input voltage is fed via an efficient filter to the interleaved switching boost converter (HR models), which provides the intermediate circuit voltage on the bulk capacitor C_b . The inrush current is limited by the resistor R_{inr} , which is shorted by V_{inr} after the bulk capacitor was charged.

The bulk capacitor sources a single-transistor forward converter with active clamp and provides the power during the interruption time of 10 ms.

The main transformer exhibits two separate secondary windings for the two outputs. The resultant voltages are rectified by synchronous rectifiers (not models with $V_o = 2 \times 48\text{ V}$) in order to provide the best efficiency. Their ripple voltages are smoothed by a dual power choke and output filters. The control logic senses the main output voltage V_{o1} and generates the control signal for the forward converter, with respect to the max. output current transferred via magnetic feedback to the control circuit of the forward converter, located on the primary side.

The second output voltage is tracking the main output, but has its own current limiting circuit. If the main output voltage drops due to current limitation, the second output voltage will drop as well and vice versa.

The output voltages can be adjusted by external means. Parallel operation of several converters is possible by interconnecting the T-pins to provide active current sharing. Both outputs can be connected in parallel or in series without any precaution. They exhibit a rectangular current limitation characteristic. Switchable preloads V_{PL} (Version V101 or later) ensure good regulation even with no load at one output.

A control output (D) and two LEDs signal correct operation of the converter. In case of an output overvoltage, the converter is disabled by a latch.

Input over- and undervoltage lockout is provided. The undervoltage trigger level can be adjusted by an external resistor connected to PUL (pin 24) depending on the nominal voltage of the supplying battery.

Temperature sensors on the primary and secondary side prevent the converter from excessive warm-up.

A cooling plate for chassis-mounting is available (opt. B, B1).

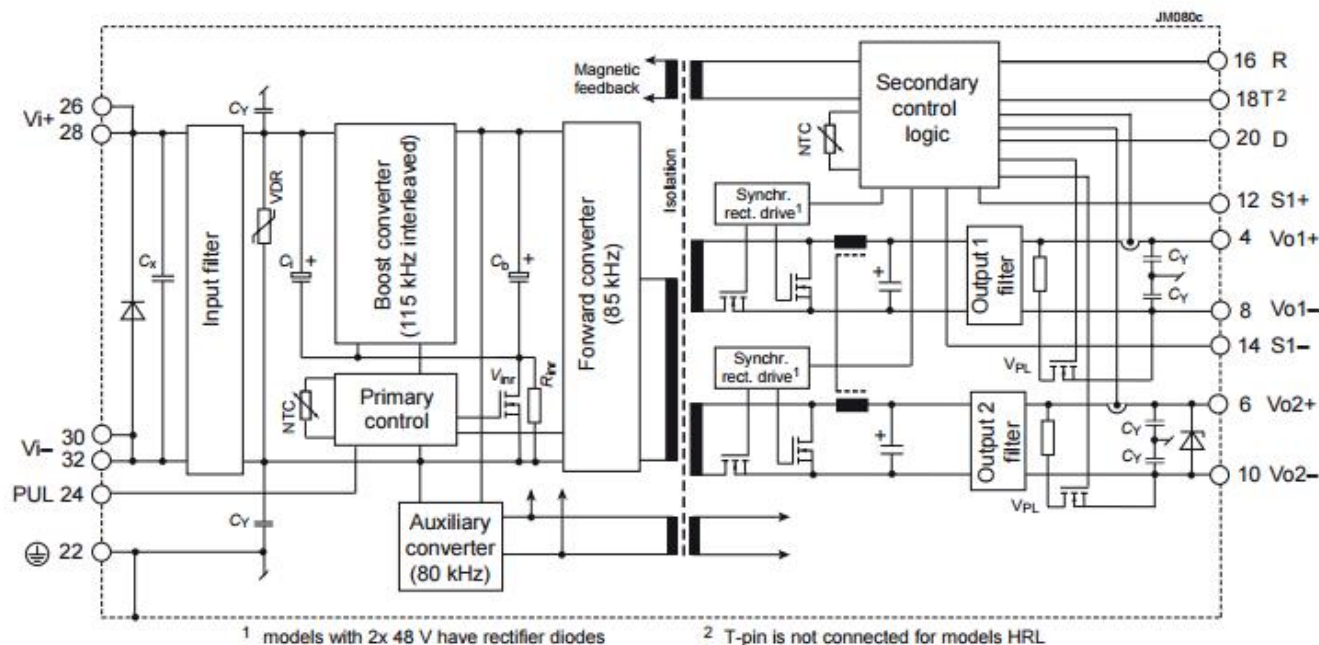

Fig. 1
Block diagram of HR2320, version V101 (or later)

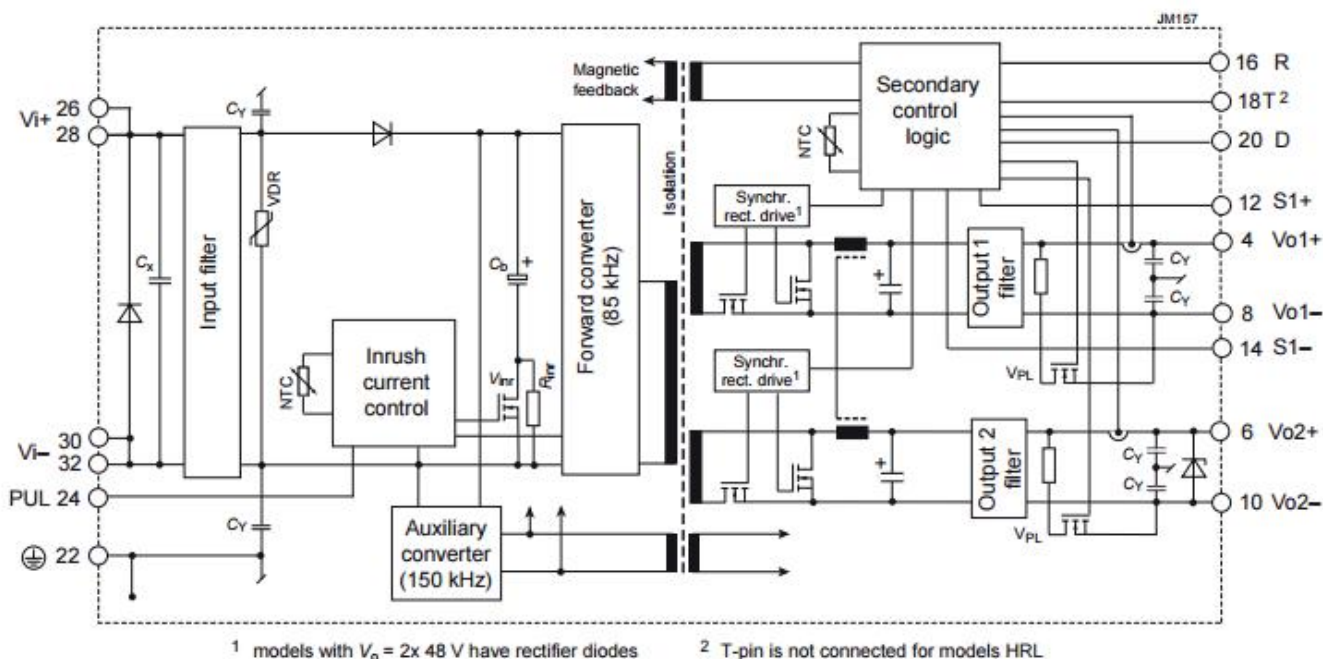

Fig. 2
Block diagram of ER2320

Electrical Input Data

General conditions:

- $T_A = 25\text{ }^\circ\text{C}$, unless T_C is specified.
- Pin 24 (PUL) left open-circuit
- Pin 16 (R) and 18 (D) left open-circuit.

Table 2a: Input data of HR models

Model		Conditions	HR			HRL			HRP			Unit	
Characteristics			min	typ	max	min	typ	max	min	typ	max		
V_i	Operating input voltage cont.	$I_o = 0 - I_{o,max}$ $T_{C,min} - T_{C,max}$	16.8		150	16.8		150	16.8		150	V	
$V_{i,2s}$	For ≤ 2 s without shutdown		12.0		168	12.0		168	12.0		168		
$V_{i,nom}$	Nominal input voltage range		24	(110)	120	24	(110)	120	24	(110)	120		
$V_{i,abs}$	Input voltage limits	3 s, without damage	0		176	0		176	0		176		
I_i	Input current: HR2320 HR2540 HR2880	$V_{i,max} \dots (110\text{ V}) \dots V_{i,min}, I_{o,nom}$	1.76	(2.36)	15.65	1.03	(1.38)	9.31	2.10	(2.83)	21.40	A	
			1.76	(2.36)	15.65								
			1.37	(1.86)	12.82								
P_{i0}	No-load input power	$V_{i,min} - V_{i,max}, I_o = 0$			11			11			11	W	
$P_{i,inh}$	Idle input power	$V_{i,min} - V_{i,max}, V_{PUL} = 0\text{ V}$			2.5			2.5			2.5		
C_x	Input capacitance ¹				8.6			8.6			8.6	μF	
R_i	Input resistance				10			10			10	$\text{m}\Omega$	
$I_{ir,p}$	Peak inrush current ²	$V_i = 150\text{ V}, I_{o,nom}$				30			30			30	mA
$t_{ir,r}$	Time constant of I_{ir}					10			10				
t_{on}	Start-up time		$0 \rightarrow V_{i,min}, I_{o,nom}$				400			400			
t_r	Rise time after inhibit	$V_i \geq 16.8\text{ V}, I_{o,nom},$ $V_{PUL} = 0 \rightarrow 5\text{ V}$				40			40				

Table 2b: Input data of ER models

Model		Conditions	ER			ERL			ERP			Unit
Characteristics			min	typ	max	min	typ	max	min	typ	max	
V_i	Operating input voltage	$I_o = 0 - I_{o,max}$ $T_{C,min} - T_{C,max}$	77		150	77		150	77		150	V
$V_{i,2s}$	For ≤ 2 s without shutdown		66		168	66		168	66		168	
$V_{i,nom}$	Nominal input voltage range			110	120			110		120		
$V_{i,abs}$	Input voltage limits	3 s, without damage	0		176	0		176	0		176	
I_i	Input current: ER2320 ER2540 ER2880	$V_{i,max} \dots (110\text{ V}) \dots V_{i,min}, I_{o,nom}$	1.76	(2.36)		1.03	(1.38)		2.10	(2.83)		A
			1.76	(2.36)								
			1.37	(1.86)								
P_{i0}	No-load input power	$V_{i,min} - V_{i,max}, I_o = 0$			10			10			10	W
$P_{i,inh}$	Idle input power	$V_{i,min} - V_{i,max}, V_{PUL} = 0\text{ V}$			2.5			2.5			2.5	
C_x	Input capacitance ¹											μF
R_i	Input resistance				10			10			10	$\text{m}\Omega$
$I_{ir,p}$	Peak inrush current ²	$V_i = 150\text{ V}, I_{o,nom}$										mA
$t_{ir,r}$	Time constant of I_{ir}											
t_{on}	Start-up time		$0 \rightarrow V_{i,min}, I_{o,nom}$				400			400		
t_r	Rise time after inhibit	$V_i \geq 77\text{ V}, I_{o,nom},$ $V_{PUL} = 0 \rightarrow 5\text{ V}$				40			40			

¹ Not smoothed by the inrush current limiter

² According to ETS 300132-2

PUL Function and Fuse

No fuse is incorporated in the converters. Consequently, an external fuse or a circuit breaker must be installed at system level to protect against severe defects.

HR converters are designed for an extremely wide input voltage range, allowing for connection to all common railway batteries. However, the programmable input undervoltage lockout (PUL, pin 24) should be adjusted adequately, in order to limit the input current at low input voltage.

Table 3 specifies the values of the resistor R_{PUL} , connected between PUL and V_{i-} , versus the resultant minimum input voltage and the recommended external input fuse.

Fig. 3 shows more values of R_{PUL} versus start-up voltage. For stationary batteries, a higher start-up voltage might be advantageous.

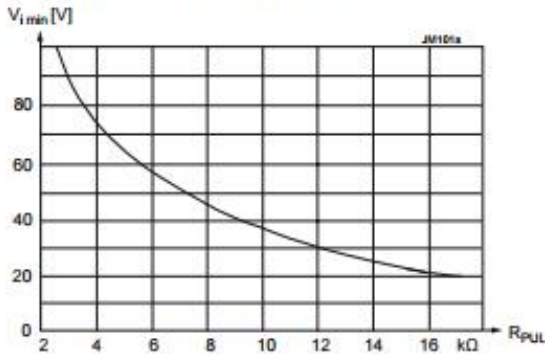

Fig. 3 R_{PUL} versus switch-on voltage (HR models)

ER models are designed for the input voltage range of a 110 V railway battery. The input undervoltage lockout (PUL, pin 24) may be adjusted if requested. The PUL resistors are specified in table 4.

Table 3: PUL Specification (typ.) and recommended external fuses for HR/HRP models. Smaller fuses are possible for HRL models.

Battery	R_{PUL}	$V_{i,min}$ (on / off)		Fuse recommended
24 V	∞	15 V	12 V ³	25 A fast, Littlefuse 314 ¹
36 V	16.9 k Ω	20 V	18 V	16 A fast, Schurter / SP ²
48 V	13.7 k Ω	26 V	20 V	12.5 A fast, Schurter / SP ²
72 V	9.5 k Ω	38 V	32 V	8 A fast, Schurter / SP ²
96 V	5.2 k Ω	62 V	57 V	6.3 A slow, BEL fuse MRT ²
110 V	2.9 k Ω	90 V	84 V	5.0 A slow, BEL fuse MRT ²
all	< 100 Ω	Converter disabled		

¹ fuse size 6.3 x 32 mm ² fuse size 5 x 20 mm ³ for ≤ 2 s

Table 4: PUL specification (typ.) and recommended external fuses for ER/ERP models. Smaller fuses are possible for ERL models.

Battery	R_{PUL}	$V_{i,min}$ (on / off)		Fuse recommended
110 V	5.0 k Ω	64.5 V	60.5 V	6.3 A slow, BEL fuse MRT ²
110 V	4.0 k Ω	74.5 V	69 V	6.3 A slow, BEL fuse MRT ²
110 V	3.0 k Ω	87.4 V	81.6 V	6.3 A slow, BEL fuse MRT ²
110 V	2.5 k Ω	96 V	90 V	6.3 A slow, BEL fuse MRT ²
120 V	2.2 k Ω	101.7 V	96 V	5.0 A slow, BEL fuse MRT ²
-	< 100 Ω	Converter disabled		

¹ fuse size 6.3 x 32 mm ² fuse size 5 x 20 mm

Note: If PUL (pin 24) is connected to V_{i-} (pin 30/32), the converter is disabled; see *Inhibit Function*.

Fig. 4 and 5 show the input current versus the input voltage.

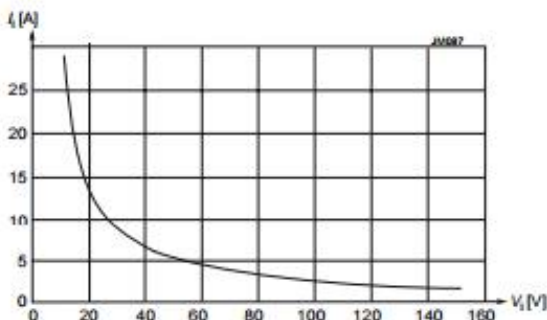

Fig. 4 Typ. input current vs input voltage at nominal load (HR2320)

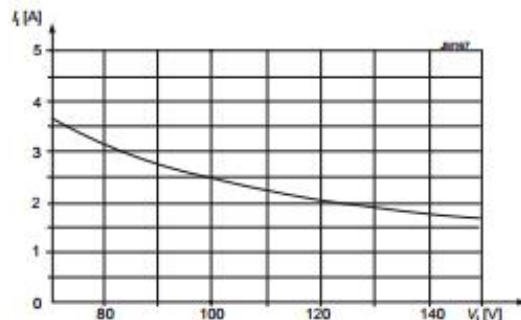

Fig. 5 Typ. input current vs input voltage at nominal load (ER2320)

Reverse Polarity and Input Transient Protection

Reverse polarity protection of all models is provided by an antiparallel diode across the input, causing the external input fuse or circuit breaker to trip. ER models exhibit an additional serial diode on the input.

The double stage symmetrical input filter together with a VDR (voltage depending resistor) form an effective protection against high input transient voltages, which typically occur in battery-driven mobile applications.

At very high input voltage, the overvoltage lockout disables the converter in order to protect it from damage.

Inrush Current Limitation

The converters exhibit an electronic inrush current limiting circuit. This circuit is also functional, when the input voltage is removed and immediately reapplied.

However, several capacitors are directly connected to the input pins. Consequently, a short current peak is present, when applying the input voltage.

The inrush current peak value can be determined by following calculation; see also fig. 6:

$$I_{inr,p} = \frac{V_{i,source}}{(R_{ext} + R_i)}$$

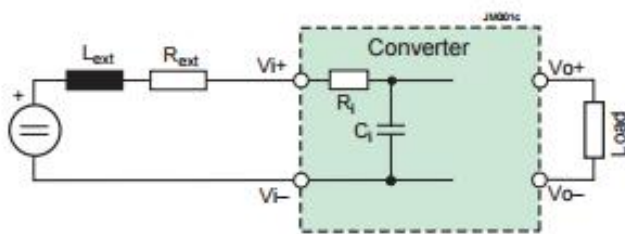

Fig. 6
Equivalent input circuit

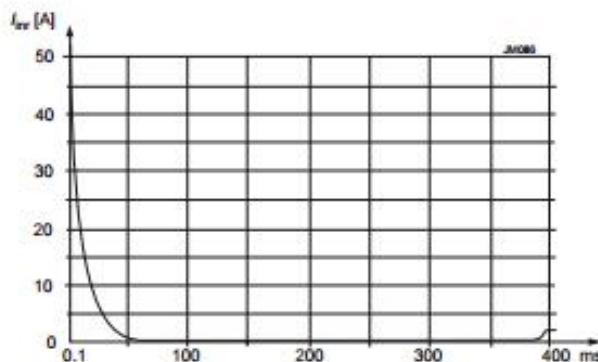

Fig. 7
Inrush current at \$V_i = 150\$ V, \$I_{o,nom}\$ (HR2320, ER2320)

Efficiency

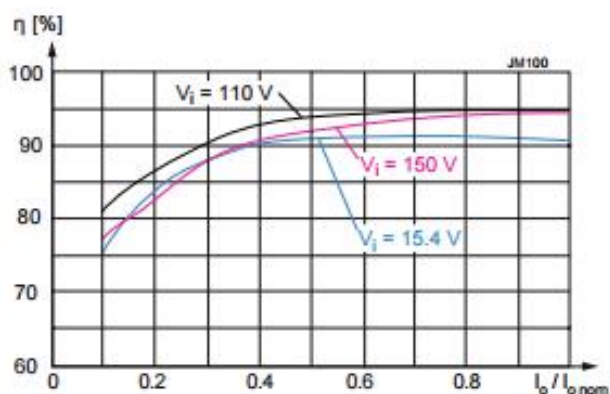

Fig. 8
Efficiency versus \$V_i\$ and \$I_o\$ (HR2320, both outputs connected in series)

Electrical Output Data

General Conditions: – $T_A = 25\text{ }^\circ\text{C}$, unless T_C is specified; Pin 24 (PUL) $\geq 5\text{ V}$

Table 5a: Output data of HR/ER2320 and HRL/ERL2320

Model		HR2320 / ER2320						HRL2320 / ERL2320						Unit	
Nom. output voltage		2 × 12 V						2 × 12 V							
Characteristics		Conditions	Output 1			Output 2			Output 1			Output 2			
			min	typ	max	min	typ	max	min	typ	max	min	typ	max	
V_o	Output voltage	$V_{I\text{nom}}, 0.5 I_{O\text{nom}}$	11.93	12.0	12.07	12.0			11.93	12.0	12.07	12.0			V
V_{oBR}	Output protection (suppressor diode)	Output 2	-			14.4	15.9			-			14.4	15.9	
I_o	Output current nom.	$\frac{V_{I\text{min}} - V_{I\text{max}}}{T_{C\text{min}} - T_{C\text{max}}}$	10			10			6.0			6.0			A
$I_{o\%}, I_{oCL}$	Output current limit ¹		10.5			10.5			6.5			6.5			
I_{o12L}	Output current limit ^{1,2}		21 ²			-			13			-			
V_o	Output noise incl. spikes	$V_{I\text{nom}}, I_{O\text{nom}}$ BW = 20 MHz	60			60			60			60			mV _{pp}
V_{oadj}	Adjustment by R-input ⁴	$\frac{V_{I\text{min}} - V_{I\text{max}}}{(0.1 - 1) I_{O\text{nom}}}$	4.8	13.8 ¹		³			4.8	13.8 ¹		³			V
ΔV_{ou}	Static line/load regulation (total deviation of V_o)		±120			³			±120			³			mV
V_{od}	Dynamic load regulation	Voltage deviation ⁵	±200			±200			±150			±150			
t_{od}	Recovery time ⁵	$\frac{V_{I\text{nom}}, 0.5 I_{O2\text{nom}}}{I_{O1\text{nom}} \leftrightarrow 0.5 I_{O1\text{nom}}}$ and after turn on	1			³			1			³			ms
α_{vo}	Temperature coefficient of output voltage	$\frac{I_{O\text{nom}}}{T_{C\text{min}} - T_{C\text{max}}}$	±0.01	±0.02		-			±0.01	±0.02		-			%/K

Table 5b: Output data of HRP/ERP2320 models

Model		HRP2320 / ERP2320						Unit	
Nom. output voltage		2 × 12 V							
Characteristics		Conditions	Output 1			Output 2			
			min	typ	max	min	typ	max	
V_o	Output voltage	$V_{I\text{nom}}, 0.5 I_{O\text{nom}}$	11.93	12.0	12.07	12.0			V
V_{oBR}	Output protection (suppressor diode)	Output 2	-			14.4	15.9		
I_o	Output current nom.	$\frac{V_{I\text{min}} - V_{I\text{max}}}{T_{C\text{min}} - T_{C\text{max}}}$	12			12			A
$I_{o\%}, I_{oCL}$	Output current limit ¹		12.3			12.3			
I_{o12L}	Output current limit ^{1,2}		24.6 ²			-			
V_o	Output noise incl. spikes	$V_{I\text{nom}}, I_{O\text{nom}}$ BW = 20 MHz	60			60			mV _{pp}
V_{oadj}	Adjustment by R-input ⁴	$\frac{V_{I\text{min}} - V_{I\text{max}}}{(0.1 - 1) I_{O\text{nom}}}$	4.8	13.8 ¹		³			V
ΔV_{ou}	Static line/load regulation (total deviation of V_o)		±120			³			mV
V_{od}	Dynamic load regulation	Voltage deviation ⁵	±250			±250			
t_{od}	Recovery time ⁵	$\frac{V_{I\text{nom}}, 0.5 I_{O2\text{nom}}}{I_{O1\text{nom}} \leftrightarrow 0.5 I_{O1\text{nom}}}$ and after turn on	1			³			ms
α_{vo}	Temperature coefficient of output voltage	$\frac{I_{O\text{nom}}}{T_{C\text{min}} - T_{C\text{max}}}$	±0.01	±0.02		-			%/K

¹ If V_o is increased above $V_{o\text{nom}}$ through R-, sense, or T-input, the output currents should be reduced so that $P_{o\text{nom}}$ is not exceeded.
² Both outputs connected in parallel
³ See *Output voltage regulation*
⁴ For battery charger application, a defined negative temp. coefficient can be provided by using a temp. sensor (see *Accessories*)
⁵ See *Dynamic load regulation*
⁶ Measured with a ceramic cap of 1 μF across each output.

Table 5c: Output data of HR/ER2540 and HRP/ERP2540. General conditions as per table 5a

Model		HR2540 / ER2540						HRP2540 / ERP2540						Unit	
Nom. output voltage		2 × 15 V						2 × 15 V							
Characteristics		Conditions	Output 1			Output 2			Output 1			Output 2			
			min	typ	max	min	typ	max	min	typ	max	min	typ	max	
V_o	Output voltage	$V_{inmin}, 0.5 I_{o, nom}$	14.91	15.0	15.09	15.0			14.91	15.0	15.09	15.0			V
V_{oBR}	Output protection (suppressor diode)	Output 2	-			20.9	23.1		-			20.9	23.1		
I_o	Output current nom.	$V_{inmin} - V_{inmax}$ $T_{Cmin} - T_{Cmax}$	8			8			9.6			9.6			A
I_{oL}, I_{oLL}	Output current limit ¹		8.4			8.4			10.1			10.1			
I_{o12L}	Output current limit ^{1,2}		16.8 ²			-			19.7 ²			-			
V_o	Output noise incl. spikes	$V_{inmin}, I_{o, nom}$ BW = 20 MHz	75			75			75			75			mV _{pp}
$V_{o, adj}$	Adjustment by R-input ⁴	$V_{inmin} - V_{inmax}$ $(0.1 - 1) I_{o, nom}$	6.0	17.25 ¹		3			6.0	17.25 ¹		3			V
ΔV_{ou}	Static line/load regulation (total deviation of V_o)		±150			3			±150			3			mV
V_{od}	Dynamic load regulation	$V_{inmin}, 0.5 I_{o2, nom}$ $I_{o1, nom} \leftrightarrow 0.5 I_{o1, nom}$ and after turn on	±300			±300			±350			±350			
t_{od}	Recovery time ⁵		1			3			1			3			
α_{vo}	Temperature coefficient of output voltage	$I_{o, nom}, T_{Cmin} - T_{Cmax}$	±0.01	±0.02		-			±0.01	±0.02		-			%/K

Table 5d: Output data of HR/ER2880 and HRP/ERP2880. General conditions as per table 5a

Model		HR2880 / ER2880						HRP2880 / ERP2880						Unit	
Nom. output voltage		2 × 48 V						2 × 48 V							
Characteristics		Conditions	Output 1			Output 2			Output 1			Output 2			
			min	typ	max	min	typ	max	min	typ	max	min	typ	max	
V_o	Output voltage	$V_{inmin}, 0.5 I_{o, nom}$	47.7	48.0	48.3	48.0			47.7	48.0	48.3	48.0			V
V_{oBR}	Output protection (suppressor diode)	Output 2	-			56.7	62.7		-			56.7	62.7		
I_o	Output current nom.	$V_{inmin} - V_{inmax}$ $T_{Cmin} - T_{Cmax}$	2			2			2.5			2.5			A
I_{oL}, I_{oLL}	Output current limit ¹		2.1			2.1			2.625			2.625			
I_{o12L}	Output current limit ^{1,2}		4.2 ²			-			5.25 ²			-			
V_o	Output noise incl. spikes	$V_{inmin}, I_{o, nom}$ BW = 20 MHz	240			240			240			240			mV _{pp}
$V_{o, adj}$	Adjustment by R-input ⁴	$V_{inmin} - V_{inmax}$ $(0.1 - 1) I_{o, nom}$	19.2	55.2 ¹		3			19.2	55.2 ¹		3			V
ΔV_{ou}	Static line/load regulation (total deviation of V_o)		±0.5			3			±0.5			3			mV
V_{od}	Dynamic load regulation	$V_{inmin}, 0.5 I_{o2, nom}$ $I_{o1, nom} \leftrightarrow 0.5 I_{o1, nom}$ and after turn on	±0.8			±0.8			±1.0			±1.0			
t_{od}	Recovery time ⁵		1			3			1			3			
α_{vo}	Temperature coefficient of output voltage	$I_{o, nom}, T_{Cmin} - T_{Cmax}$	±0.01	±0.02		-			±0.01	±0.02		-			%/K

¹ If the output voltages are increased above $V_{o, nom}$ through R-input control, remote sensing, or option T, the output currents should be reduced accordingly so that $P_{o, nom}$ is not exceeded.
² Both outputs connected in parallel
³ See *Output voltage regulation*
⁴ For battery charger applications, a defined negative temperature coefficient can be provided by using a temperature sensor (see *Accessories*)
⁵ See *Dynamic load regulation*
⁶ Measured with a ceramic cap of 1 µF across each output.

Thermal Considerations

If a converter is located in free, quasi-stationary air (convection cooling) at the indicated maximum ambient temperature $T_{A\max}$ (see table *Temperature specifications*) and is operated within the specified input voltage range and nominal load, the temperature measured at the *Measuring point of case temperature* T_C (see *Mechanical Data*) will approach the indicated value $T_{C\max}$ after the warm-up phase. However, the relationship between T_A and T_C depends heavily upon the conditions of operation and integration into a system. The thermal conditions are influenced by input voltage, output current, airflow, and temperature of surrounding components and surfaces. $T_{A\max}$ is therefore, contrary to $T_{C\max}$, an indicative value only; see also fig. 9.

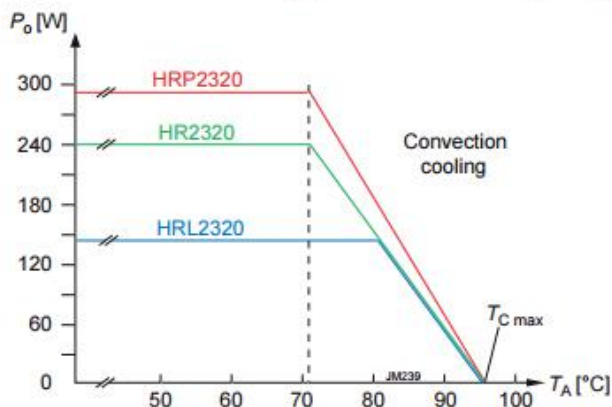

Fig. 9
Power derating for HRP/HR/HRL2320

Caution: The installer must ensure that under all operating conditions T_C remains within the limits stated in the table *Temperature specifications*.

Notes: Sufficient forced cooling or enhanced cooling with the help of cooling plates (options B, B1) allows for T_A to be higher than 71 °C (e.g. 85 °C), as long as $T_{C\max}$ is not exceeded.

Thermal Protection

Two temperature sensors generate an internal inhibit signal, which disables the converter in the case of overtemperature. The outputs automatically recover when the temperature drops below the limit.

Interruption Time

The integrated storage capacitor (C_b) is loaded to the boost voltage and ensures full output voltage with nominal load during an interruption time (or ride-through time) of at least 10 ms, provided that V_i was ≥ 20 V before the interruption. This complies with EN 50155:2017 class S2.

Output Protection

The 2nd output of double-output models is protected by a suppressor diode against overvoltage, which could occur due to a failure of the internal control circuit. This suppressor diode was not designed to withstand externally applied overvoltages. Overload at any of the outputs will cause both outputs to shut down.

Note: V_{oBR} of the suppressor diode is specified in *Electrical Output Data*. If this voltage is exceeded, the suppressor diode generates losses and may become a short circuit.

Note: The output voltage of the first output is monitored. If it exceeds typ. 140% of $V_{o\text{nom}}$ for 10 ms, the converter is inhibited. To reactivate, V_i must be removed or an inhibit signal must be applied to PUL (pin 24).

Each output has its own current limiting circuit, providing a rectangular output characteristic and protecting against short circuit. There is no limitation for the capacitive load, and battery charging is possible as well.

Series and Parallel Connection

Both outputs of the same converter can be series-connected or parallel-connected in order to double the output current or the output voltage respectively.

Outputs of different converters may be series-connected.

In parallel connection of several converters, the T-pins should be interconnected so that all converters share the output current equally; see fig. 10. HRL and ERL models have no T-pins and should not be operated in parallel connection.

If both outputs of each converter are connected in series, Vo1- of both converters should be connected together and the T-pins as well. See fig. 11.

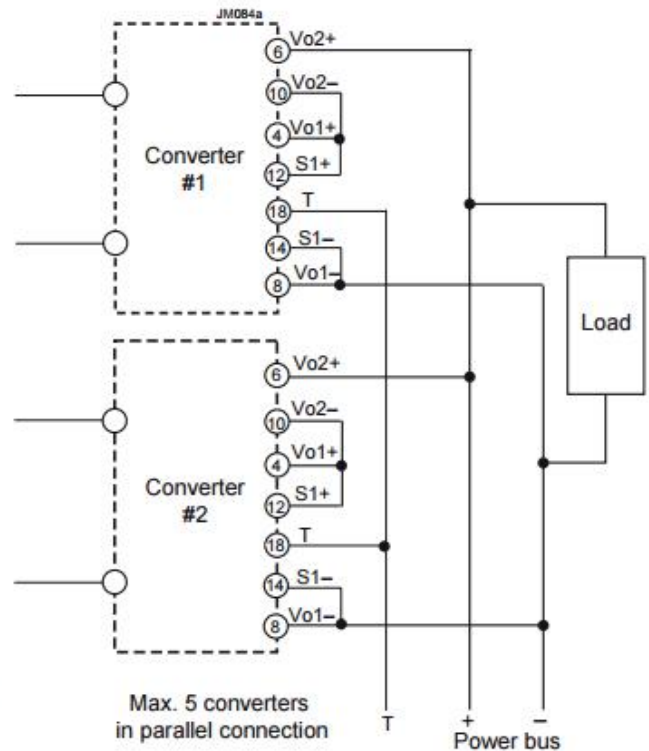
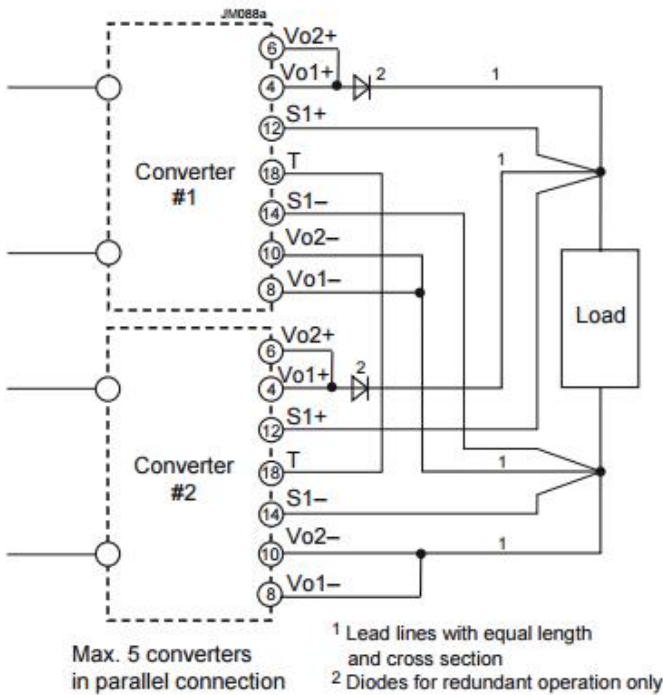

Fig. 10
Parallel connection with OR-ing diodes and sense lines connected at the load

Fig. 11
Parallel connection of double-output models with the outputs of each converter connected in series, using option T. The signal at the T pins are referenced to Vo1-.

Notes:

- Not more than 5 converters should be connected in parallel.
- If several outputs are connected in series, the resulting voltage can exceed the SELV level.
- The PUL- pins (pin 24) should exhibit an individual PUL resistor for each converter. If the shutdown function is used, each PUL-pin must be controlled individually.
- The R-pins should be left open-circuit. If not, the output voltages must individually be adjusted prior to paralleling within 1 to 2% or the R-pins should be connected together.
- Series connection of second outputs without involving their main outputs should be avoided, as regulation may be poor.

Output Voltage Regulation

If both outputs are connected in parallel or in series, the converter exhibits a rectangular output characteristic; see fig. 12. The typ. dynamic load regulation illustrates fig. 13.

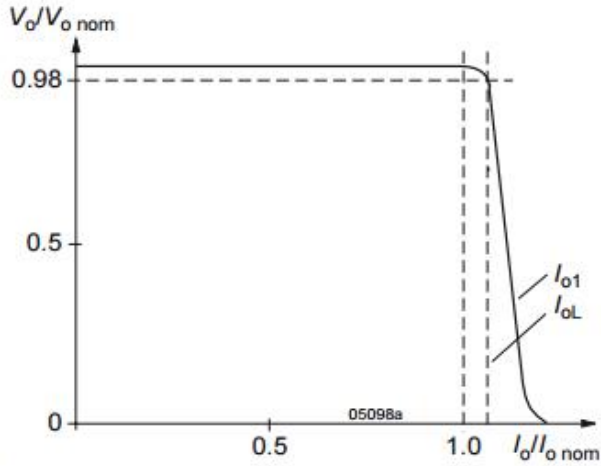

Fig. 12
Output characteristic V_o versus I_o
(both outputs connected in parallel or in series)

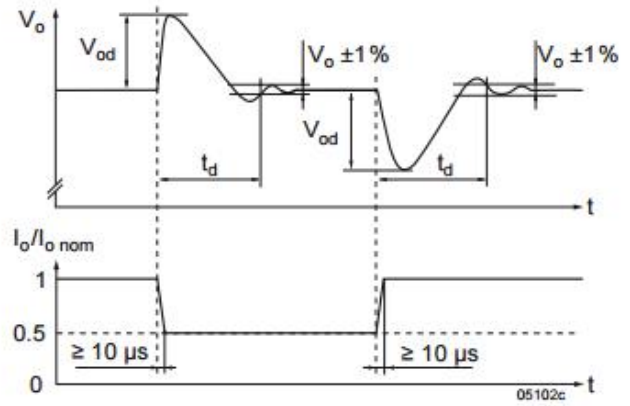

Fig. 13
Typical dynamic load regulation of V_o

Output 1 is under normal conditions regulated to $V_{o,nom}$, irrespective of the output currents.

However, V_{o2} depends upon the load distribution; see fig. 14 a and fig. 14b. Converters with version V101 (or later) have incorporated switchable preloads and do not need a minimum load.

Note: If output 2 is not used, connect it with output 1 ! This ensures good voltage regulation and efficiency.

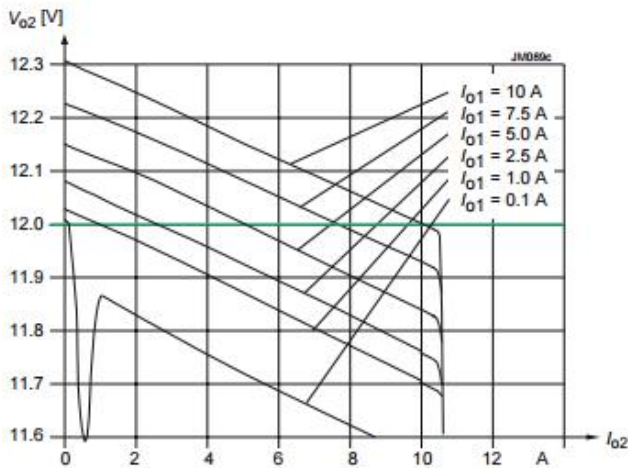

Fig. 14a
Models HR/ER2320: V_{o2} versus I_{o2} with various I_{o1}

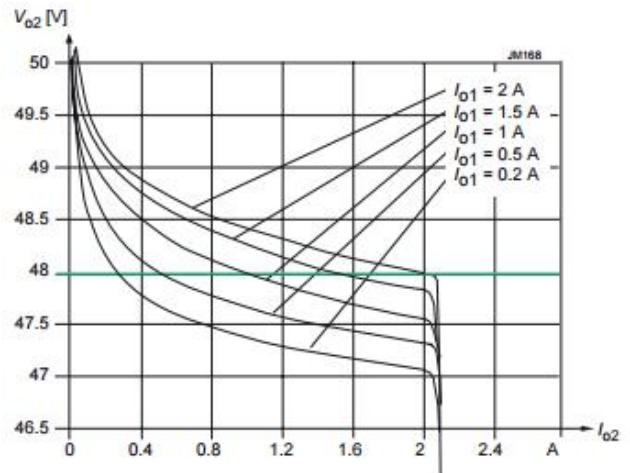

Fig. 14b
Models HR/ER2880: V_{o2} versus I_{o2} with various I_{o1}

Auxiliary Functions

Inhibit Function

The PUL input (pin 24) can also be used as inhibit (for the PUL function see table 3 and 4). The response time t_{on} and the rise time t_r are specified in table 2.

The current coming out from pin 24 (PUL) is typ. 1.5 mA (<2 mA). If pin 24 is left open-circuit, the voltage is typ. 5 V. The converter is disabled when V_{PUL} is ≤ 500 mV.

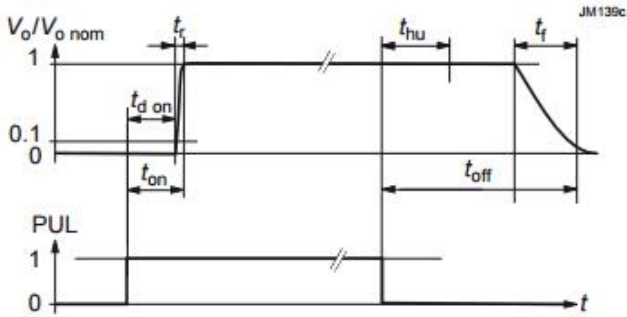

Fig. 15
Typical output response to the PUL-signal (inhibit)

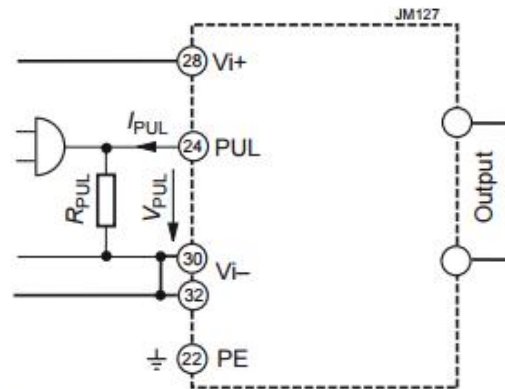

Fig. 16
Circuit for the inhibit function

Current Share Function

If the pins 18 (T) of parallel-connected converters are connected together, the converters share the output current evenly. Refer to section *Parallel and Series Connection*. Not for HRL and ERL models.

Sense Lines

This feature allows for compensation of voltage drops across the connector contacts and if necessary, across the load lines. We recommend connecting the sense lines directly at the female connector.

To ensure correct operation, both sense lines (S1+, S1-) should be connected to their respective power outputs (Vo1+ and Vo1-), and the voltage difference between any sense line and its respective power output (as measured on the connector) should not exceed the values specified in table 6.

Table 6: Maximum voltage compensation allowed using sense lines

Output voltage	Total voltage difference between sense lines and their respective outputs	Voltage difference between Vo1- and S1-
12 V	< 1.00 V	< 0.5 V
15 V	< 1.25 V	< 0.6 V
48 V	< 2.00 V	< 1.0 V

Important: Sense lines should be connected! Incorrectly connected sense lines may activate the overvoltage protection resulting in a permanent short-circuit of the output. Open sense lines are allowed, but result in inaccurate output voltages.

Output Voltage Adjust

As a standard feature, the converters offer an adjustable output voltage. The control input R (pin 16) accepts either a control voltage V_{ext} or a resistor R_{ext} to adjust the output voltage. When input R is not connected, the output voltage is set to $V_{o,nom}$.

a) Adjustment by means of an **external control voltage** V_{ext} between pin 16 (R) and pin 14 (S1-):

The control voltage range is 1.0 – 2.875 V and allows for an adjustment in the range of approx. 40 – 115% of $V_{o,nom}$.

$$V_{ext} \approx \frac{V_o \cdot 2.5 V}{V_{o,nom}}$$

Caution: Applying an external control voltage >2.875V may damage the converter.

b) Adjustment by means of an **external resistor**:

Depending on the value of the required output voltage, the resistor shall be connected

either: between pin 16 (R) and pin 14 (S1-) to adjust the output voltage in the range of approx. 40 – 100% of $V_{o,nom}$.

$$R_{ext1} \approx 4 k\Omega \cdot \frac{V_o}{V_{o,nom} - V_o}$$

or: between pin 16 (R) and pin 12 (S1+) to adjust the output voltage in the range of 100 – 115% of $V_{o,nom}$.

$$R_{ext2} \approx 4 k\Omega \cdot \frac{(V_o - 2.5 V)}{2.5 V \cdot (V_o/V_{o,nom} - 1)}$$

Caution: To prevent the converter from damage, the value of R'_{ext} shall never be less than the value for increasing V_{o1} to 115% !

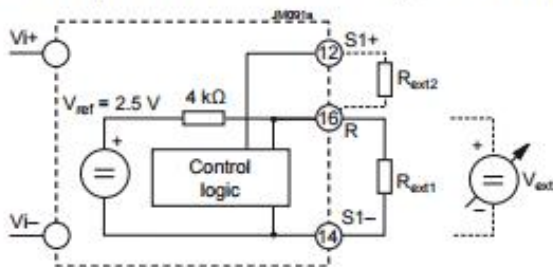

Fig. 17
Output voltage adjustment

Notes:

- If the output voltages are increased above $V_{o,nom}$ via R-input control, sense lines, or option T, the output currents should be reduced, so that $P_{o,nom}$ is not exceeded.
- The second output of double-output models follows the voltage of the controlled main output.

Output Voltage Monitor

The output voltage monitor generates a logic "low" signal (NPN open-collector output) at the D-output (pin 20), when $V_{o1} \geq 0.96 V_{o,nom}$. For converters with version V101 (or later), the voltage at S1+ (corresponding to V_{o1}) must be $\geq 0.96 V_{o,nom}$ and $\leq 1.04 V_{o,nom}$ (typ. values). Then, a green LED (Out OK) at the frontplate is illuminated. If the output voltage is adjusted by the R-input, the trigger levels are corrected accordingly.

At low D-output, the current is limited by a 10 Ω protective resistor; for converters with Version V102 (or later) I_D should be ≤ 100 mA. If the D-output is high (open collector), V_D should be ≤ 75 V. For previous converters: ≤ 50 mA and 50 V.

Note: Output overvoltage activates a latch; see *Output Protection*.

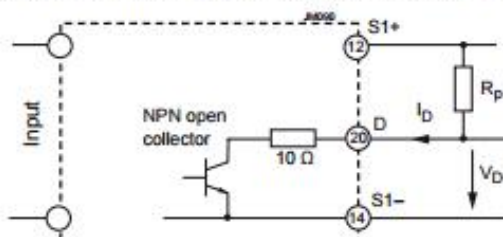

Fig. 18
Output voltage monitor

Indicators

Two green LED indicators are visible at the front plate:

- Out OK; see *Output Voltage Monitor*
- In OK. This signal is activated when V_i is below 158 V and greater than $V_{i\ min}$, whereas $V_{i\ min}$ is defined by the adjust resistor connected to the PUL input (pin 24).

Battery Charging / Temperature Sensor

All converters with an R-input are suitable for battery charger application. For optimal battery charging and life expectancy of the battery an external temperature sensor can be connected to the R-input. The sensor is mounted as close as possible to the battery and adjusts the output voltage according to the battery temperature.

Depending upon cell voltage and the temperature coefficient of the battery, different sensor types are available; see *Accessories*.

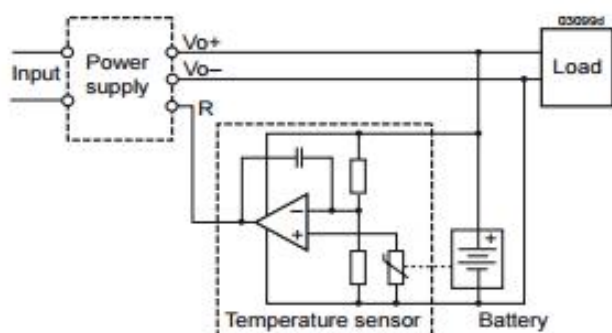

Fig. 19
Connection of a temperature sensor

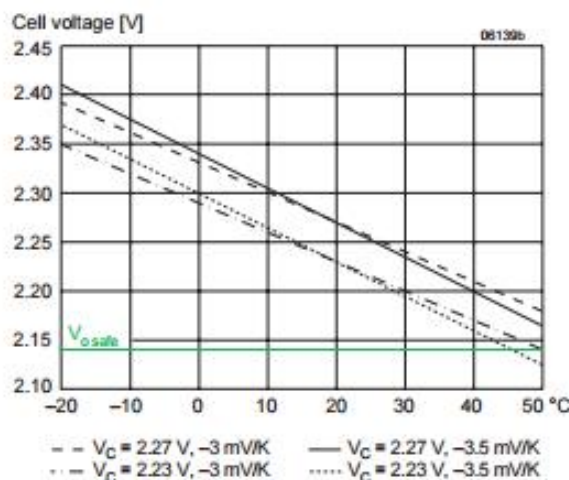

Fig. 20
Trickle charge voltage versus temperature for defined temp. coefficient. $V_{0\ nom}$ is the output voltage with open R-input.

Electromagnetic Compatibility (EMC)

A metal oxide VDR together and an efficient input filter form an effective protection against high input transient voltages, which typically occur in most installations. The converters have been successfully tested to the following specifications:

Electromagnetic Immunity

Table 7: Electromagnetic immunity (type tests)

Phenomenon	Standard	Level	Coupling mode ¹	Value applied	Waveform	Source imped.	Test procedure	In oper.	Perf. crit. ²
Electrostatic discharge (to case)	IEC/EN 61000-4-2	4 ³	contact discharge	8000 V _p	1/50 ns	330 Ω 150 pF	10 pos. & 10 neg. discharges	yes	A
			air discharge	15000 V _p					
Electromagnetic field	IEC/EN 61000-4-3	x ⁴	antenna	20 V/m	AM 80% / 1 kHz	N/A	800 – 1000 MHz	yes	A
				10 V/m			1400 – 2000 MHz		
				5 V/m			2000 – 2500 MHz		
				3 V/m			5100 – 6000 MHz		
		3	antenna	10 V/m	50% duty cycle, 200 Hz rep. rate	N/A	900 ±5 MHz pulse modul.	yes	A
Electrical fast transients / burst	IEC/EN 61000-4-4	3 ⁶	capacitive, o/c ¹	±2000 V _p	bursts of 5/50 ns; 2.5 / 5 kHz over 15 ms; burst period: 300 ms	50 Ω	60 s positive 60 s negative transients per coupling mode	yes	A
		4	i/c, +i/-i ¹ direct	±4000 V _p					
Surges	IEC/EN 61000-4-5	3 ⁷	i/c ¹	±2000 V _p	1.2 / 50 μs	42 Ω 0.5 μF	5 pos. & 5 neg. surges per coupling mode	yes	A
			+i/-i ¹	±1000 V _p					
Conducted disturbances	IEC/EN 61000-4-6	3 ⁸	i, o, signal wires	10 VAC (140 dBμV)	AM 80% / 1 kHz	150 Ω	0.15 – 80 MHz	yes	A
Power frequency magnetic field	IEC/EN 61000-4-8	3 ⁹	-	300 A/m			60 s in all 3 axes	yes	A
Pulse magnetic field	IEC/EN 61000-4-9	-	-	±300 A/m			5 pulses per axis repetit. rate 10 s	yes	A

¹ i = input, o = output, c = case

² A = normal operation, no deviation from specs.; B = normal operation, temporary loss of function or deviation from specs possible

³ Exceeds EN 50121-3-2:2016 table 5.3 and EN 50121-4:2016 table 2.4.

⁴ Corresponds to EN 50121-3-2:2016 table 5.1 and exceeds EN 50121-4:2016 table 2.1.

⁵ Corresponds to EN 50121-3-2:2016 table 5.2 and EN 50121-4:2016 table 2.2 (compliance with digital communication devices).

⁶ Corresponds/exceeds EN 50121-3-2:2016 table 3.2 and EN 50121-4:2016 table 4.2.

⁷ Covers EN 50121-3-2:2016 table 5.3 and EN 50121-4:2016 table 4.3.

⁸ Corresponds to EN 50121-3-2:2016 table 3.1 and EN 50121-4:2016 table 4.1 (radio frequency common mode).

⁹ Corresponds to EN 50121-4:2016 table 2.3.

Electromagnetic Emissions

All conducted emissions (fig. 21 and 22) have been tested according to EN 55011, group 1, class A. These limits are much stronger than requested in EN 50121-3-2:2016, table 2.1, and coincide with EN 50121-4:2016, table 1.1. The limits in fig. 21 and 22 apply to quasipeak values, which are always lower than peak values.

In addition, the values for average must hold a limit 10 dBµV below the limits in fig. 21 and 22 (not shown).

Radiated emissions have been tested according to EN 55011, group 1, class A. These limits are similar to the requirements of EN 50121-3-2:2016 and EN 50121-4:2016, both calling up EN 61000-6-4+A1:2011, table 1. The tests were executed with horizontal and vertical polarization. The worse result is shown in fig. 22 and 23.

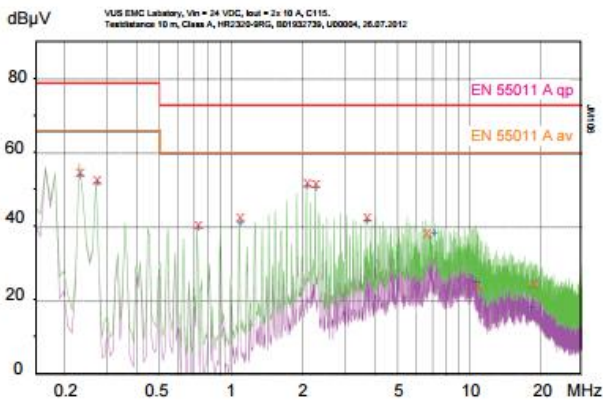

Fig. 21
Typ. conducted emissions (peak/quasipeak and average) at the input, measured at $V_i = 24\text{ V}$ and $I_{o\text{ nom}}$ (HR2320-9RG).

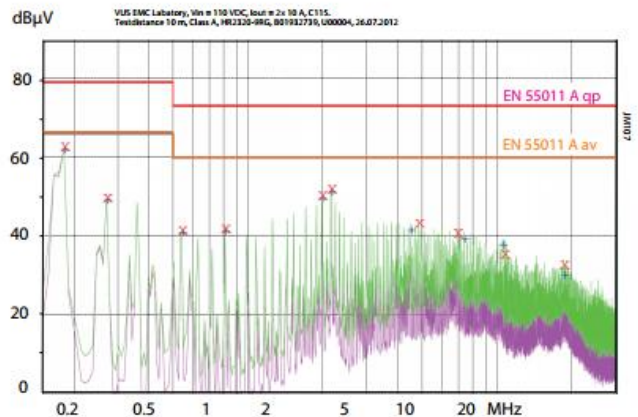

Fig. 22
Typ. conducted emissions (peak/quasipeak and average) at the input, measured at $V_i = 110\text{ V}$ and $I_{o\text{ nom}}$ (HR2320-9RG, ER2320-9RG).

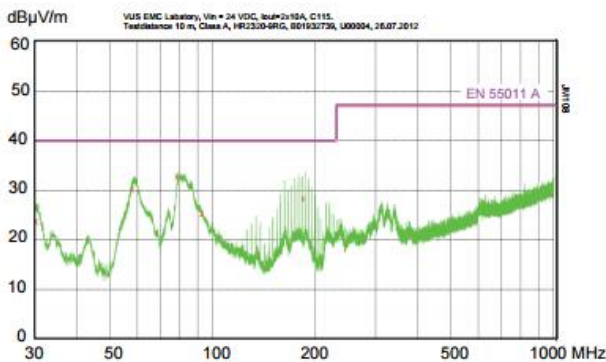

Fig. 23
Typ. radiated emissions in 10 m distance, measured at $V_i = 24\text{ V}$ and $I_{o\text{ nom}}$ (HR2320-9RG).

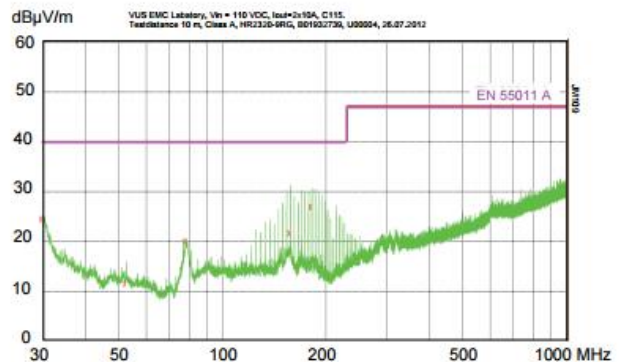

Fig. 24
Typ. radiated emissions in 10 m distance, measured at $V_i = 110\text{ V}$ and $I_{o\text{ nom}}$ (HR2320-9RG, ER2320-9RG).

Immunity to Environmental Conditions

Table 8: Mechanical and climatic stress

Test method		Standard	Test Conditions		Status
Cab	Damp heat steady state	IEC/EN 60068-2-78 MIL-STD-810D section 507.2	Temperature: Relative humidity: Duration:	40 ^{±2} °C 93 ^{+2/-3} % 56 days	Converter not operating
Db 2	Cyclic damp heat test	EN 50155:2017, clause 13.4.7 IEC/EN 60068-2-30	Temperature: Cycles (respiration effect) Duration:	55 °C and 25 °C 2 2x 24 h	Converter not operating
Be	Dry heat test steady state	EN 50155:2017, clause 13.4.5 IEC/EN 60068-2-2	Temperature: Duration:	70 °C 6 h	Converter operating
Ad	Low temperature start-up test	EN 50155:2017, clause 13.4.4 IEC/EN 60068-2-1	Temperature, duration: Performance test:	-40 °C, 2 h +25 °C	Converter not operating
Ka	Salt mist test sodium chloride (NaCl) solution	EN 50155:2017, clause 13.4.10	Temperature: Duration:	35 ^{±2} °C 48 h	Converter not operating
Fc	Vibration (sinusoidal)	IEC/EN 60068-2-6 MIL-STD-810D section 514.3	Acceleration amplitude: Frequency (1 Oct/min): Test duration:	0.35 mm (10 – 60 Hz) 5 g _n = 49 m/s ² (60 - 2000 Hz) 10 – 2000 Hz 7.5 h (2.5 h in each axis)	Converter operating
Fh	Random vibration broad band (digital control) & guidance	IEC/EN 60068-2-64	Acceleration spectral density: Frequency band: Acceleration magnitude: Test duration:	0.05 g _n ² /Hz 8 – 500 Hz 4.9 g _{n,rms} 1.5 h (0.5 h in each axis)	Converter operating
Ea	Shock (half-sinusoidal)	IEC/EN 60068-2-27 MIL-STD-810D section 516.3	Acceleration amplitude: Bump duration: Number of bumps:	50 g _n = 490 m/s ² 11 ms 18 (3 in each direction)	Converter operating
-	Shock	EN 50155:2017 clause 13.4.11, EN 61373:2010 sect. 10, class B, body mounted ¹	Acceleration amplitude: Bump duration: Number of bumps:	5.1 g _n 30 ms 18 (3 in each direction)	Converter operating crit. A
-	Simulated long life testing at increased random vibration levels	EN 50155:2017 clause 13.4.11.2, EN 61373:2010 sect. 8 and 9, class B, body mounted ¹	Acceleration spectral density: Frequency band: Acceleration magnitude: Test duration:	0.02 g _n ² /Hz 5 – 150 Hz 0.8 g _{n,rms} 15 h (5 h in each axis)	Converter operating crit. A

¹ Body mounted = chassis of a railway coach

Temperatures

Table 9: Temperature specifications, valid for an air pressure of 800 – 1200 hPa (800 – 1200 mbar)

Model		-9			Unit	
Characteristics	Conditions	min	typ	max		
T_A	Ambient temperature	Converter operating		- 40	71 ¹	°C
T_C	Case temperature			- 40	95 ^{1 2}	
T_S	Storage temperature	Not operational		- 55	85	

¹ See *Thermal Considerations*.

² Overtemperature lockout at $T_C > 95$ °C (An NTC resistor on primary and secondary heatsink).

Reliability

Table 10: MTBF and device hours

Ratings at specified case temperature	Model	Ground benign 40 °C	Ground fixed		Ground mobile 50 °C	Life test ¹ 25 °C	Device hours ²	Unit
			40 °C	70 °C				
Bellcore SR332	HR2320	352 000	176 000	49 000	38 000	500 000		h

¹ Life test with 32 converters during 26 days, cycling at 60 °C; confidence level 60%.

² Statistical values, based on an average of 4300 working hours per year and in general field use over 5 years; upgrades and customer-induced errors are excluded.

Mechanical Data

Dimensions in mm. The converters are designed to be inserted into a 19" rack, 160 mm long, according to IEC 60297-3.

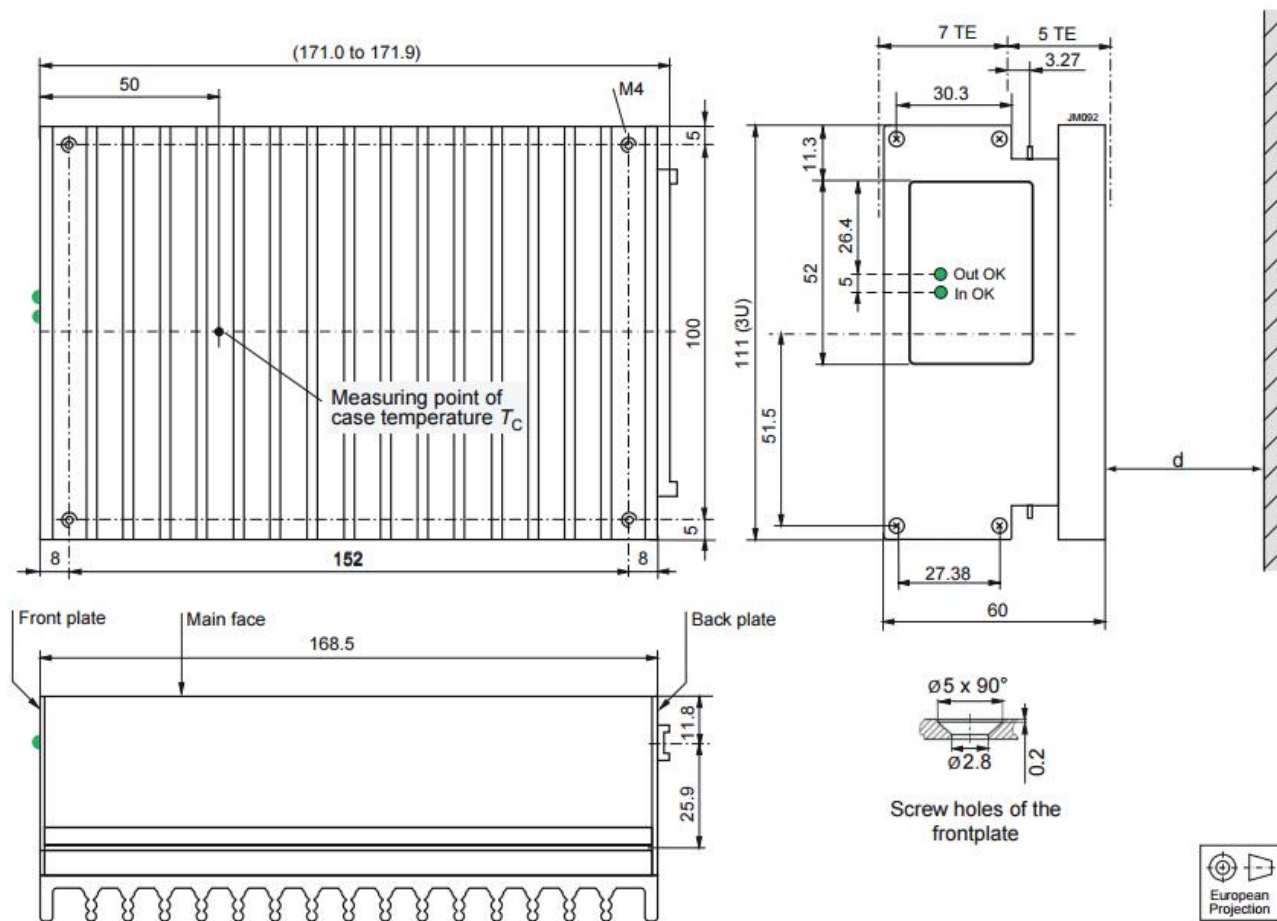

Fig. 25
Case S03 for HR and ER models with heat sink;
Aluminum, black finish (EP powder coated);
weight approx. 1.5 kg

Notes:

- $d \geq 15$ mm, recommended minimum distance to next part in order to ensure proper air circulation at full output power.
- free air location: the converter should be mounted with fins in a vertical position to achieve maximum airflow through the heat sink.

Dimensions in mm. The converters are designed to be inserted into a 19" rack, 160 mm long, according to IEC 60297-3.

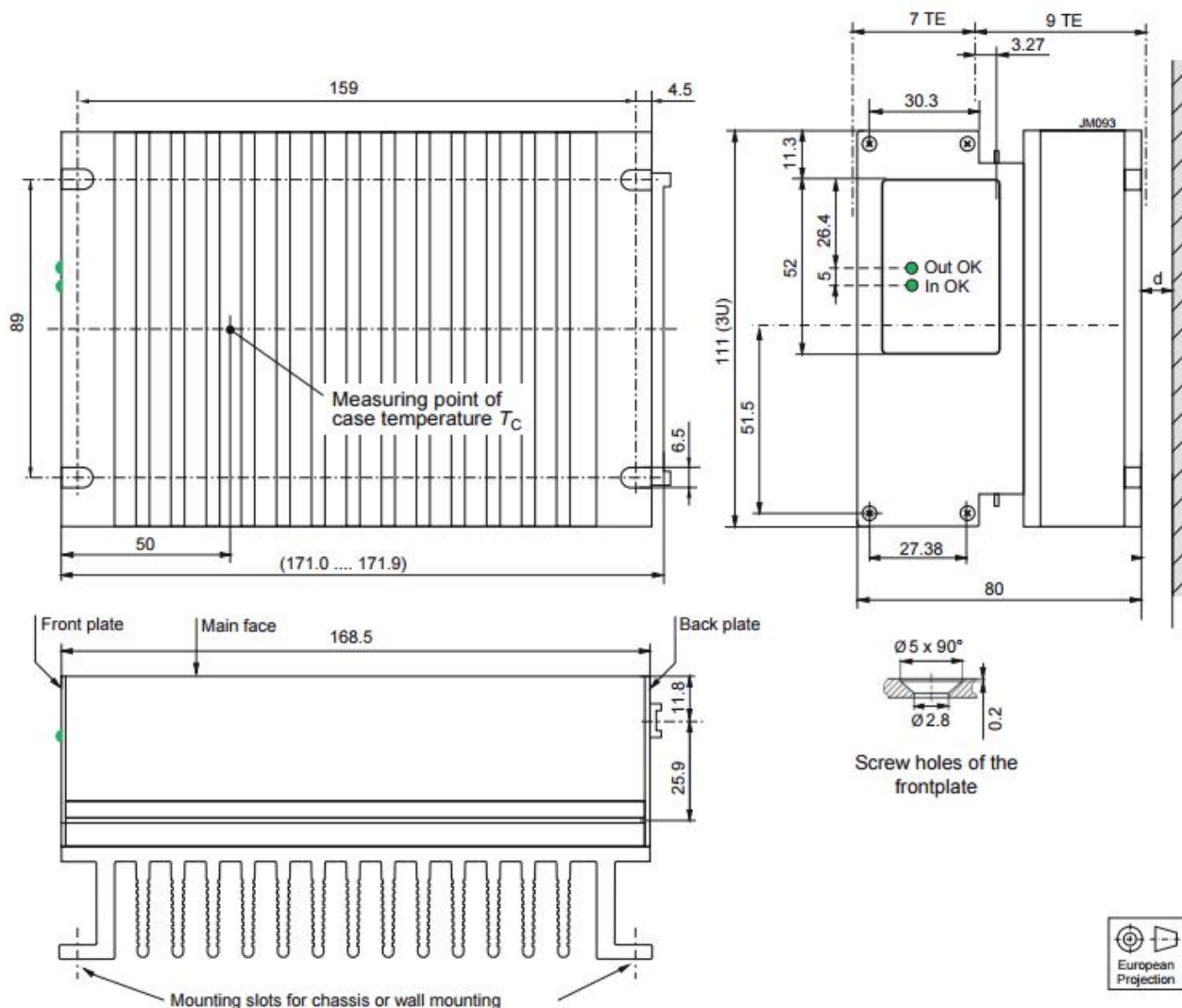

Fig. 26
Case K03 for HRP and ERP models with heat sink;
Aluminum, black finish (EP powder coated);
weight approx. 1.8 kg

Notes:

- $d \geq 15$ mm, recommended minimum distance to next part in order to ensure proper air circulation at full output power.
- free air location: the converter should be mounted with fins in a vertical position to achieve maximum airflow through the heat sink.

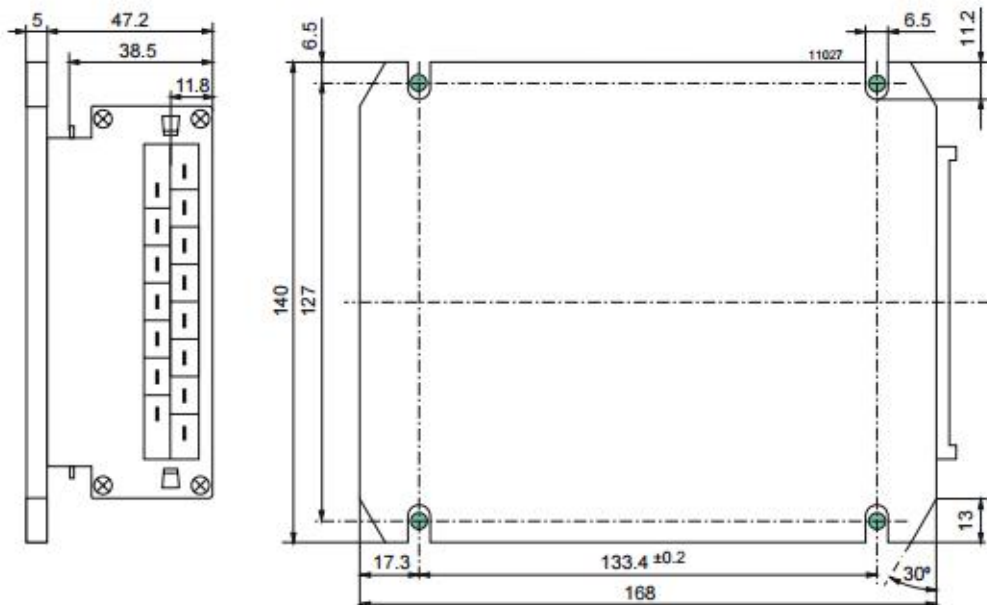

Fig. 27
Option B: Aluminum case S03 with large cooling plate; black finish (EP powder coated).
Suitable for front mounting.
Total weight approx. 1.5 kg

Note: Long case with option B2, elongated by 60 mm for 220 mm rack depth, is available on request. (No LEDs)

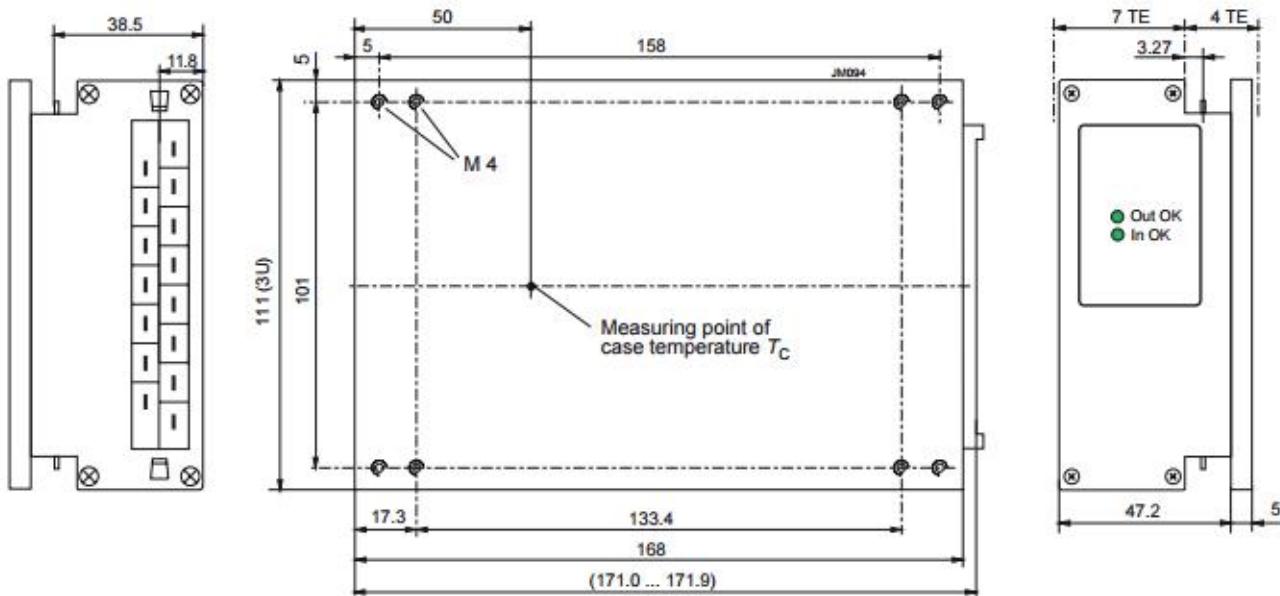

Fig. 28
Option B1: Aluminum case S03 with small cooling plate; black finish (EP powder coated).
Suitable for mounting with access from the backside.
Total weight approx. 1.4 kg.

Connector Pin Allocation

The connector pin allocation table defines the electrical potentials and the physical pin positions on the H15 connector. The protective earth is connected by a leading pin (no. 24), ensuring that it makes contact with the female connector first.

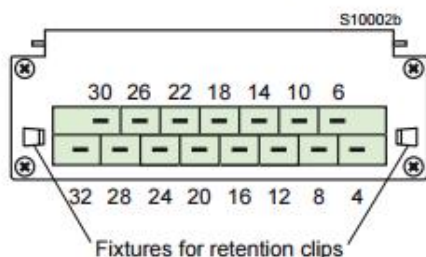

Fig. 29
View of module's male connectors

Table 11: Pin allocation

Pin	Name	Function
4	Vo1+	Output 1 positive
6	Vo2+	Output 2 positive
8	Vo1-	Output 1 negative
10	Vo2-	Output 2 negative
12	S1+	Sense line positive
14	S1-	Sense line negative
16	R	Output voltage adjust
18 ²	T	Current share
20	D	Out OK
22 ¹	PE	Protection earth
24	PUL	Programmable undervoltage lockout
26 + 28	Vi+	Input positive
30 + 32	Vi-	Input negative

¹ Leading pin (pre-connecting)

² Not connected for HRL models

Installation Instructions

The converters are components, intended exclusively for inclusion within other equipment by an industrial assembly operation or by professional installers. Installation must strictly follow the national safety regulations in compliance with the enclosure, mounting, creepage, clearance, casualty, markings, and segregation requirements of the end-use application.

Connection to the system shall be made via the female connector H15; see *Accessories*. Other installation methods may not meet the safety requirements.

Pin no. 22 () is connected with the case. For safety reasons it is essential to connect this pin reliably to protective earth.

Notes:

- The PUL function (pin 24) must be programmed to enable the outputs. PUL should be connected to Vi- (pins 30 + 32) by a resistor to adjust the start-up voltage; see table 3. Otherwise, the input current may become too high at low input voltage.
- Do not open the converter, or warranty will be invalidated.
- If the second output is not used, connect it in parallel with the main output.

Make sure that there is sufficient airflow available for convection cooling and verify it by measuring the case temperature T_c , when the converter is installed and operated in the end-use application; see *Thermal Considerations*.

Ensure that a converter failure (e.g. an internal short-circuit) does not result in a hazardous condition.

Standards and Approvals

The converters are safety-approved to UL/CSA 60950-1 2nd Ed. and IEC/EN 60950-1 2nd Ed.

The converters correspond to Class I equipment (with case connected to ground). They have been evaluated for:

- Building-in
- Basic insulation between input and case based on 250 VA. Double or reinforced insulation between input and outputs
- Functional insulation between outputs
- Overvoltage category II
- Pollution degree 2 environment
- Max. altitude: 2000 m
- The converters fulfill the requirements of a fire enclosure.

The output voltage is considered as SELV, except HR/HRP/ER/ERP2880 with both outputs in series connection.

The converters are subject to manufacturing surveillance in accordance with the above mentioned standards and ISO 9001:2015. CB-scheme is available on request.

Protection Degree and Cleaning Liquids

The protection degree is IP 40, provided that the female connector is fitted to the converter.

In order to avoid possible damage, any penetration of cleaning fluids has to be prevented, since the power supplies are not hermetically sealed.

Railway Application and Fire Protection

The converters have been designed by observing the railway standards EN 50155, EN 50121-3-2, and EN 50121-4. All boards are coated with a protective lacquer.

The converters comply with NF-F16 (I2/F1). They also comply with EN 45545-1, EN 45545-2, if installed in a technical compartment or cabinet.

Isolation and Protective Earth

The electric strength test is performed in the factory as routine test according to EN 50514 and IEC/EN 60950 and should not be repeated in the field. The Company will not honor warranty claims resulting from incorrectly executed electric strength tests. The resistance case to the earth pin (<0.1 Ω) is tested with 25 A for 1 s.

Table 12: Isolation

Characteristics		Input to Case + Outputs	Output(s) to Case	Output 1 to Output 2	Unit
Electric strength test	Factory test 10 s	2.8 ¹	1.4	0.3	kVDC
	AC test voltage equivalent to factory test	2.0	1.0	0.21	kVAC
Insulation resistance		>300	>300	>100 ²	MΩ
Creepage distances		≥ 3.5 ³	≥ 2.5	-	mm

¹ According to EN 50514 and IEC/EN 60950, subassemblies connecting input to output are pre-tested with 5.6 kVDC or 4 kVAC.

² Tested at 150 VDC

³ Input to outputs: 6.4 mm

Description of Options

B, B1 Cooling Plates

Where a cooling surface is available, we recommend the use of a cooling plate instead of the standard heat sink. The mounting system should ensure that the maximum case temperature $T_{c \max}$ is not exceeded. The cooling capacity is calculated by (η see *Model Selection*):

$$P_{\text{Loss}} = \frac{(100\% - \eta)}{\eta} \cdot V_o \cdot I_o$$

For the dimensions of the cooling plates; see *Mechanical Data*.

ACCESSORIES

A variety of electrical and mechanical accessories are available including:

- Front panels for 19" DIN-rack: Schroff or Intermax, 12 or 16TE /3U; see fig. 30 and the data sheet BCD.00495.
- Mating H15 connectors with screw, solder, faston, or press-fit terminals; see fig. 31
- Coding clips for connector coding HZZ00202
- Pair of connector retention clips HZZ01209-G; see fig. 32
- Connector retention brackets HZZ01216-G; see fig. 33
- Cage clamp adapter HZZ00144-G; see fig. 34
- Cable hood for H15 connectors (fig 35):
 - HZZ00141-G, screw version
 - HZZ00142-G, use with retention brackets HZZ01218-G
 - HZZ00143-G, metallic version providing fire protection
- Wall-mounting plate K02 (HZZ01213-G) for models with option B1; see fig. 36
- DIN-rail mounting assembly HZZ0615-G (DMB-K/S); see fig. 37
- Additional external input and output filters
- Different battery sensors S-KSMH... for using the converter as a battery charger. Different cell characteristics can be selected; see fig. 38, table 13, and *Battery Charging/ Temperature Sensors*.

For additional accessory product information, see the accessory data sheets listed with each product series or individual model at our web site belfuse.com/power-solutions.



Fig. 30
Different front panels



Fig. 31
Different mating connectors



Fig.32
Connector retention clips to fasten the H15 connector to the rear plate; see fig. 29. HZZ01209-G consists of 2 clips.

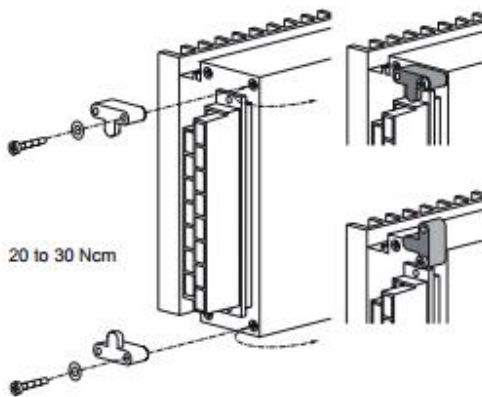

Fig. 33
Connector retention brackets HZZ01216-G

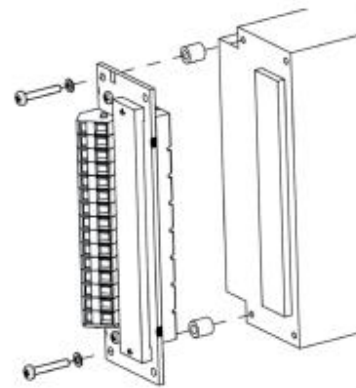

Fig. 34
Cage clamp adapter HZZ00144-G



Fig. 35
Different cable hoods



Fig. 36
Chassis- or wall-mounting plate HZZ01213-G (Mounting plate K02)



Fig. 37
DIN-rail mounting assembly HZZ00615-G (DMB-K/S)

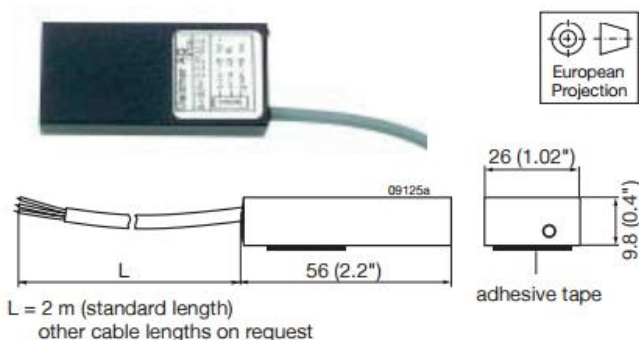

Fig. 38
Battery temperature sensor

Table 13: Battery temperature sensors

Battery voltage nom. [V]	Sensor type	Cell voltage [V]	Cell temp. coefficient [mV/K]	Cable length [m]
12	S-KSMH12-2.27-30-2	2.27	-3.0	2
12	S-KSMH12-2.27-35-2	2.27	-3.5	2
24	S-KSMH24-2.27-30-2	2.27	-3.0	2
24	S-KSMH24-2.27-35-2	2.27	-3.5	2
24	S-KSMH24-2.31-35-0	2.31	-3.5	4.5
24	S-KSMH24-2.31-35-2	2.31	-3.5	2
24	S-KSMH24-2.35-35-2	2.35	-3.5	2
48	S-KSMH48-2.27-30-2	2.27	-3.0	2
48	S-KSMH48-2-27-35-2	2.27	-3.5	2

NUCLEAR AND MEDICAL APPLICATIONS - These products are not designed or intended for use as critical components in life support systems, equipment used in hazardous environments, or nuclear control systems.

TECHNICAL REVISIONS - The appearance of products, including safety agency certifications pictured on labels, may change depending on the date manufactured. Specifications are subject to change without notice.

泰达华芯科技

西安泰达华芯科技有限公司

电话/传真: 029-85395956 邮箱: sales@power-teda.com

地址: 西安市雁塔区长安南路 98 号长延居 2 幢 2 单元 16 层

北京泰达华芯科技发展有限公司

电话: 010-59458529 电话: 010-57425478

邮箱: sales@power-teda.com

地址: 北京市海淀区清河三旗桥东南 95 号楼 408 室